

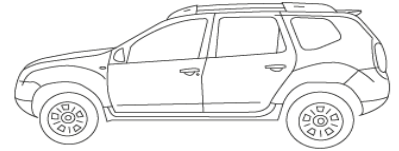

DUSTER

PH.2 :11/2013



82 01 271 007

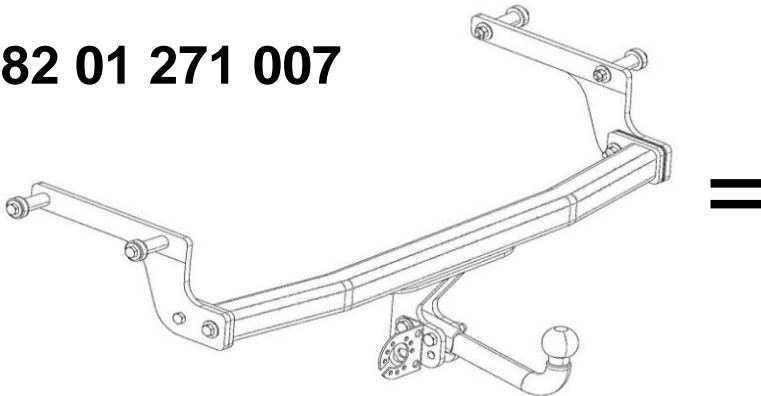

82 01 271 008

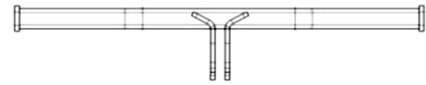

+

82 01 271 010



82 01 536 476

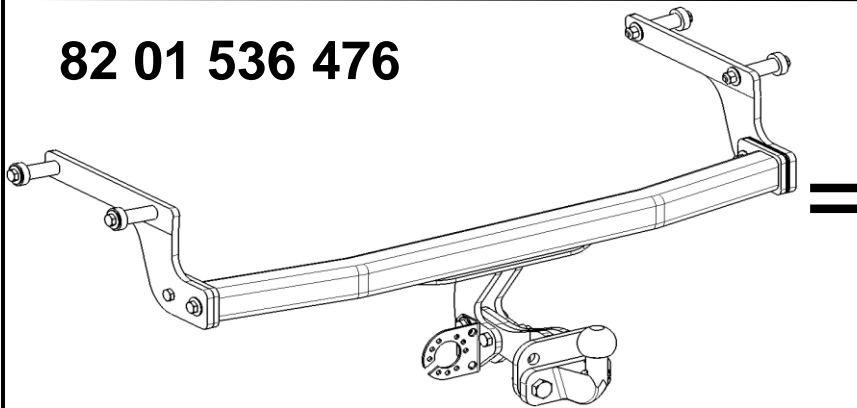

82 01 536 480

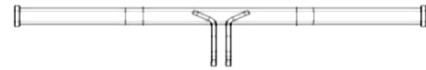

+

82 01 536 481

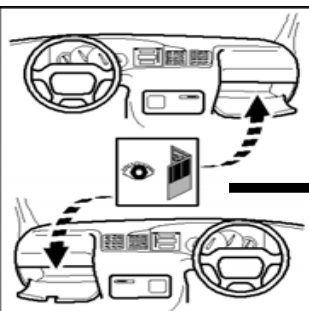
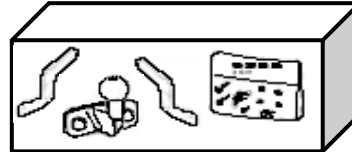

TYPE MINES :
HS****

<http://www.tech-accessoires.renault.com>

(FRA)

Instructions de montage

(CZA)

Pokyny pro montáž

(DAN)

Monteringsveiledning

(DEU)

Einbauanleitung

(ENG)

Installation instructions

(ESP)

Istrucciones de montaje

(EST)

Paigaldusjuhised

(FIN)

Asenusohje

(GRK)

Οδηγίες συναρμολόγησης

(CRO)

Návody k montáži

(HUN)

Beépítési utasítások

(ITA)

Istruzioni per il montaggio

(JPN)

取付説明書

(KOR)

조립설명서

(LTH)

Montavimo instrukcija

(LET)

Montāžas instrukcijas

(NLD)

Inbouwhandleiding

(NOR)

Monteringsveiledning

(PLK)

Instrukcje wbudowania

(PTG)

Instruções de montagem

(ROM)

Instructiuni de montaj

(RUS)

Инструкция по монтажу

(SLK)

Návod na zabudovanie

(SLV)

Navodila za inštalacijo

(SWE)

Montageanvisning

(TRK)

Montaj talimatları

RENAULT
CLASS : A 50 X
 N° Homologation ECER55

E24	55R-01 0295*03	D	8,62 kN
		S	75 kg

TYPE

SI 182	Réf.	82 01 536 476
--------	------	---------------

SIARR Made in FRANCE

RENAULT
CLASS : A 50 X
 N° Homologation ECER55

E24	55R-01 0295*02	D	8,62 kN
		S	75 kg

TYPE

SI 182	Réf.	82 01 271 007
--------	------	---------------

SIARR Made in FRANCE

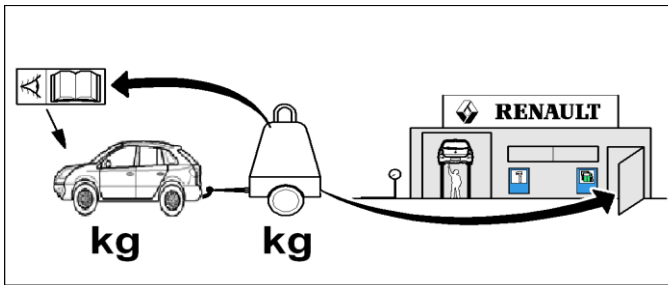

D-value

$$D = \frac{\text{Car} \times \text{Truck}}{\text{Car} + \text{Truck}} \times \frac{9,81}{1000} = 8,62 \text{ kN}$$

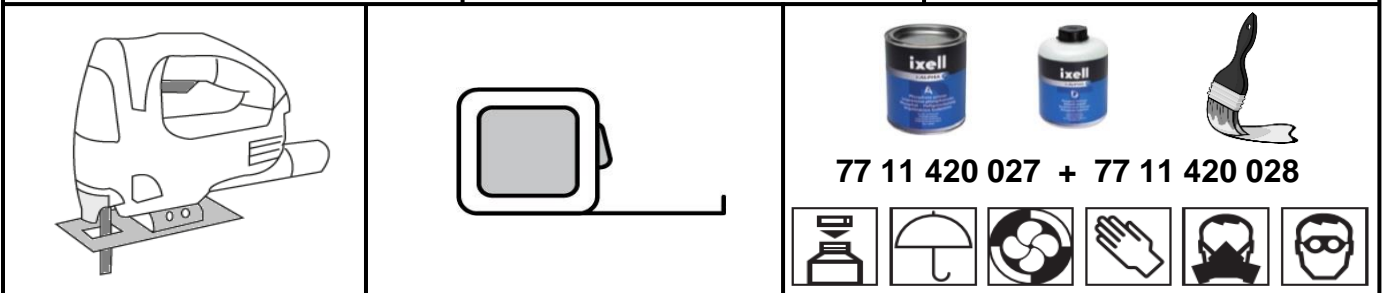
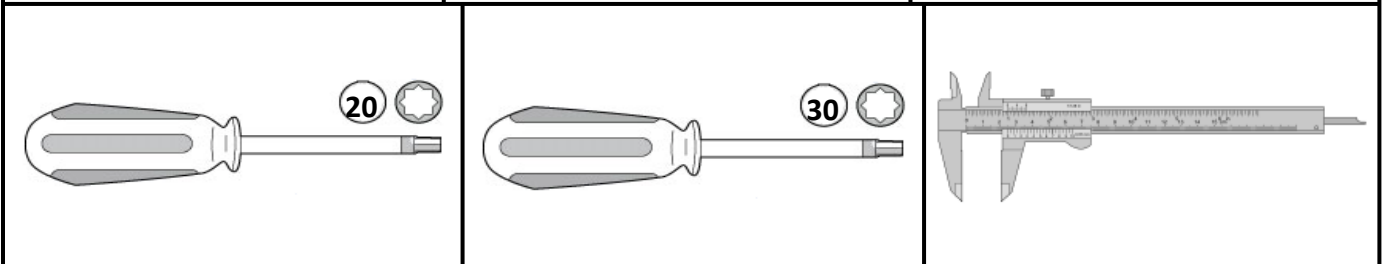
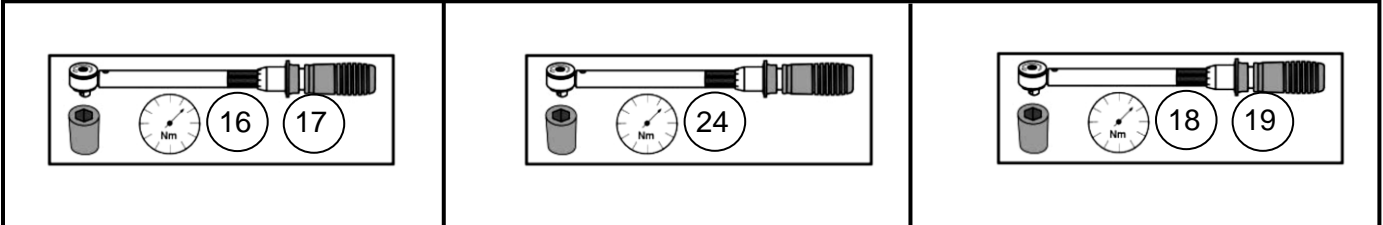
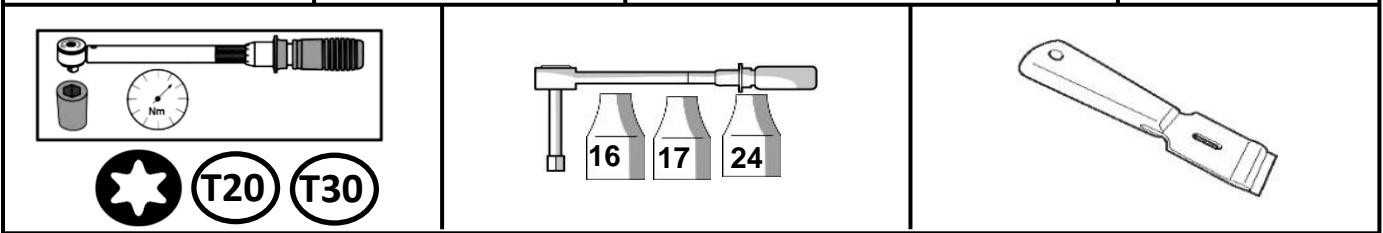
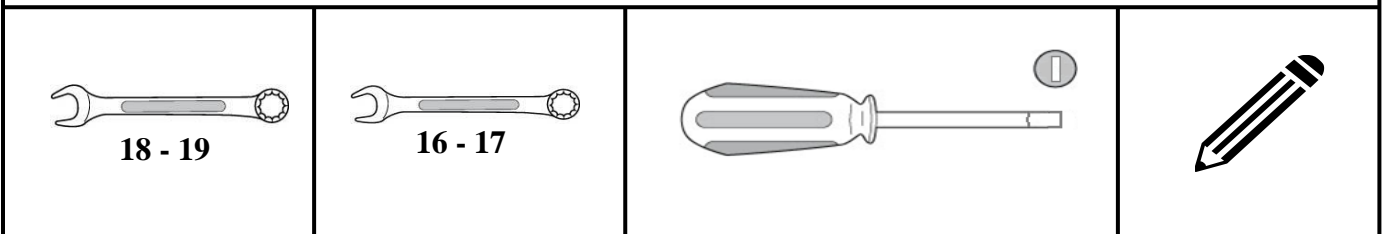

82 01 271 007

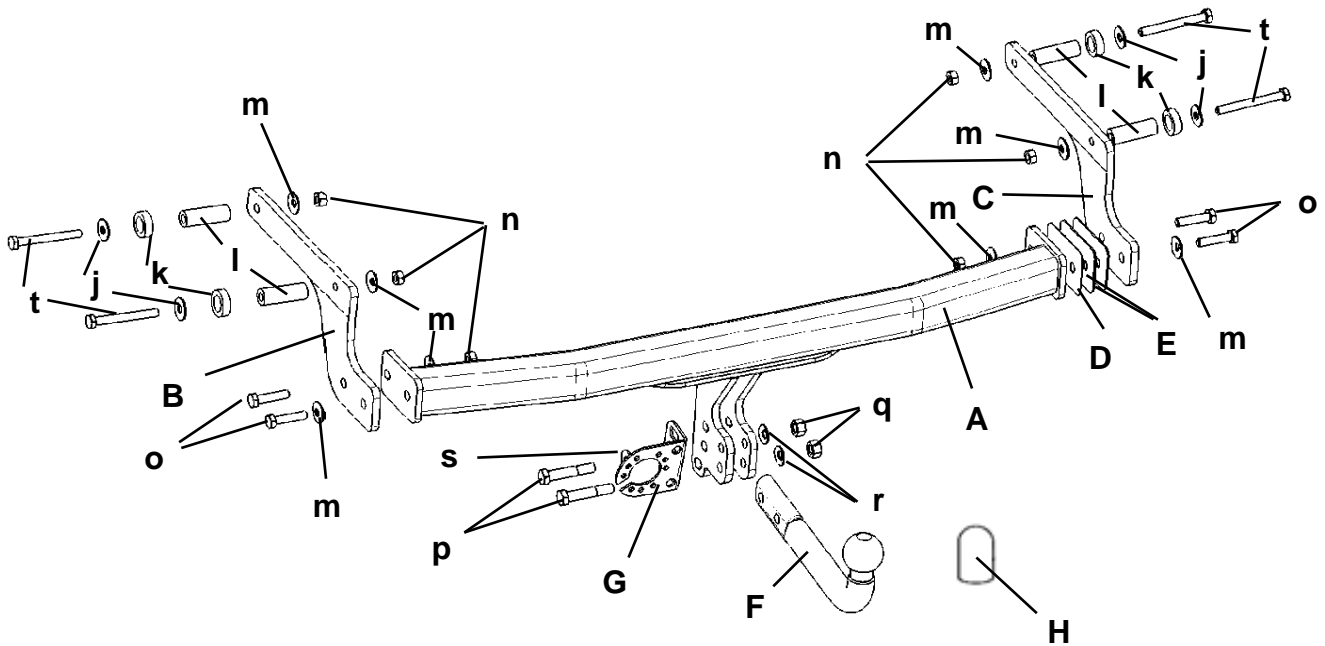

A : 1
B : 1
C : 1
D : 2 1 mm
E : 4 2 mm
F : 1
G : 1
H : 1

j : 4 L 10,5 x 27
k : 4 20/32 x 10
l : 4 10,5/20 x 60
m : 8 CS10 x 20
n : 6 M 10 Cl 10
o : 4 HM 10 x 45 Cl 10.9 60Nm
p : 2 HM 12 x 65 Cl 10.9 100 Nm
q : 2 M 12 Cl 10
r : 2 CS12 x 24
s : 1 L 12 x 30 x 3
t : 4 HM 10 x 95 Cl 10.9 60Nm



M10- cl 10.9 - 60 Nm
M12 - cl 10.9 - 100 Nm

82 01 536 476

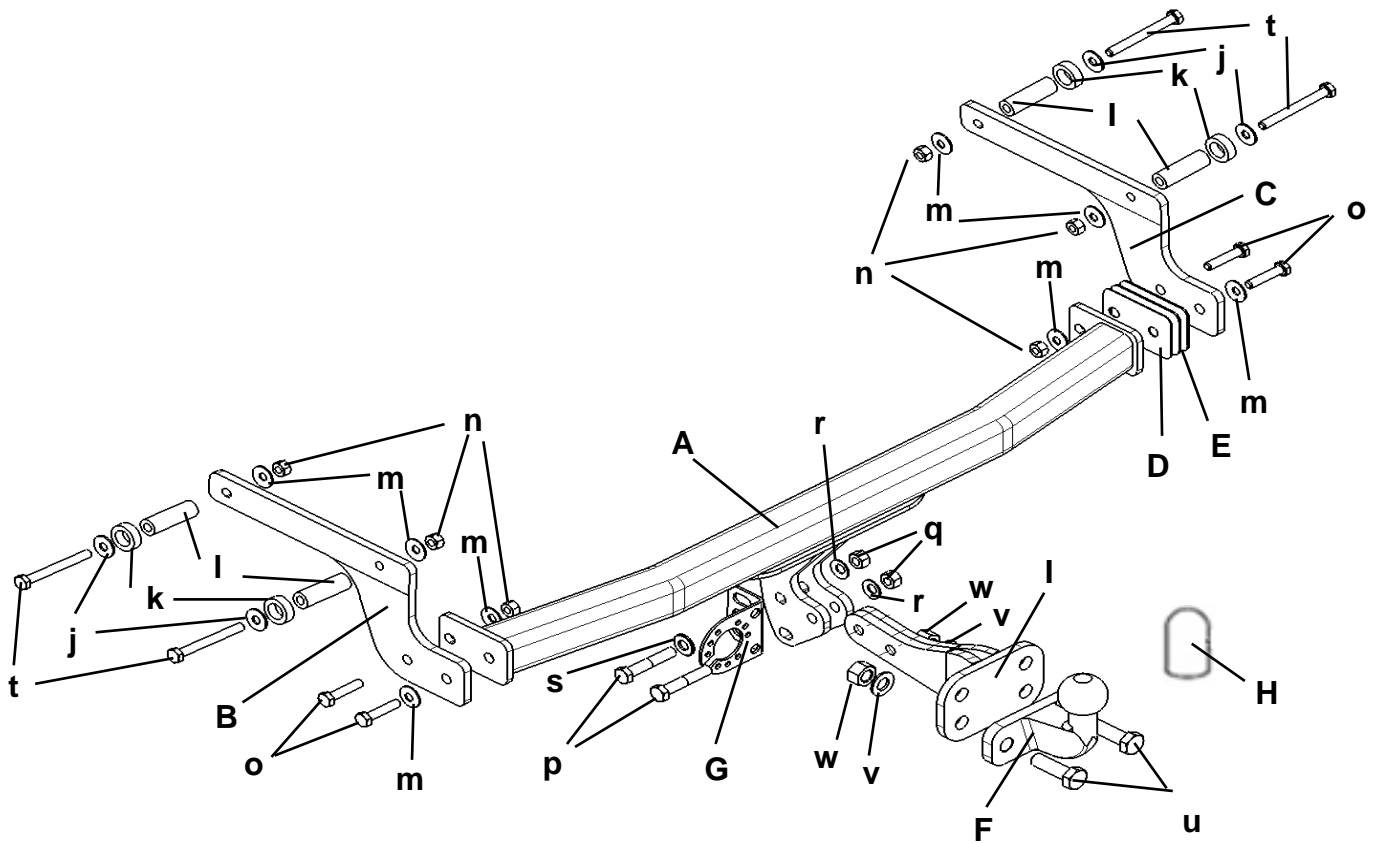

A : 1
B : 1
C : 1
D : 2 1 mm
E : 4 2 mm
F : 1
G : 1
H : 1
I : 1

j : 4 L 10,5 x 27
k : 4 20/32 x 10
l : 4 10,5/20 x 60
m : 8 CS10 x 20
n : 6 M 10 CI 10
o : 4 HM 10 x 45 CI 10.9 60Nm
p : 2 HM 12 x 65 CI 10.9 100 Nm
q : 2 M 12 CI 10
r : 2 CS12 x 24
s : 1 L 12 x 30 x 3
t : 4 HM 10 x 95 CI 10.9 60Nm
u : 2 HM 16 x 50 CI 8.8 195 Nm
v : 2 CS16 x 32
w : 2 M16 CI 8



M10 - cl 10.9 - 60 Nm
M12 - cl 10.9 - 100 Nm
M16 - cl 8.8 - 195 Nm

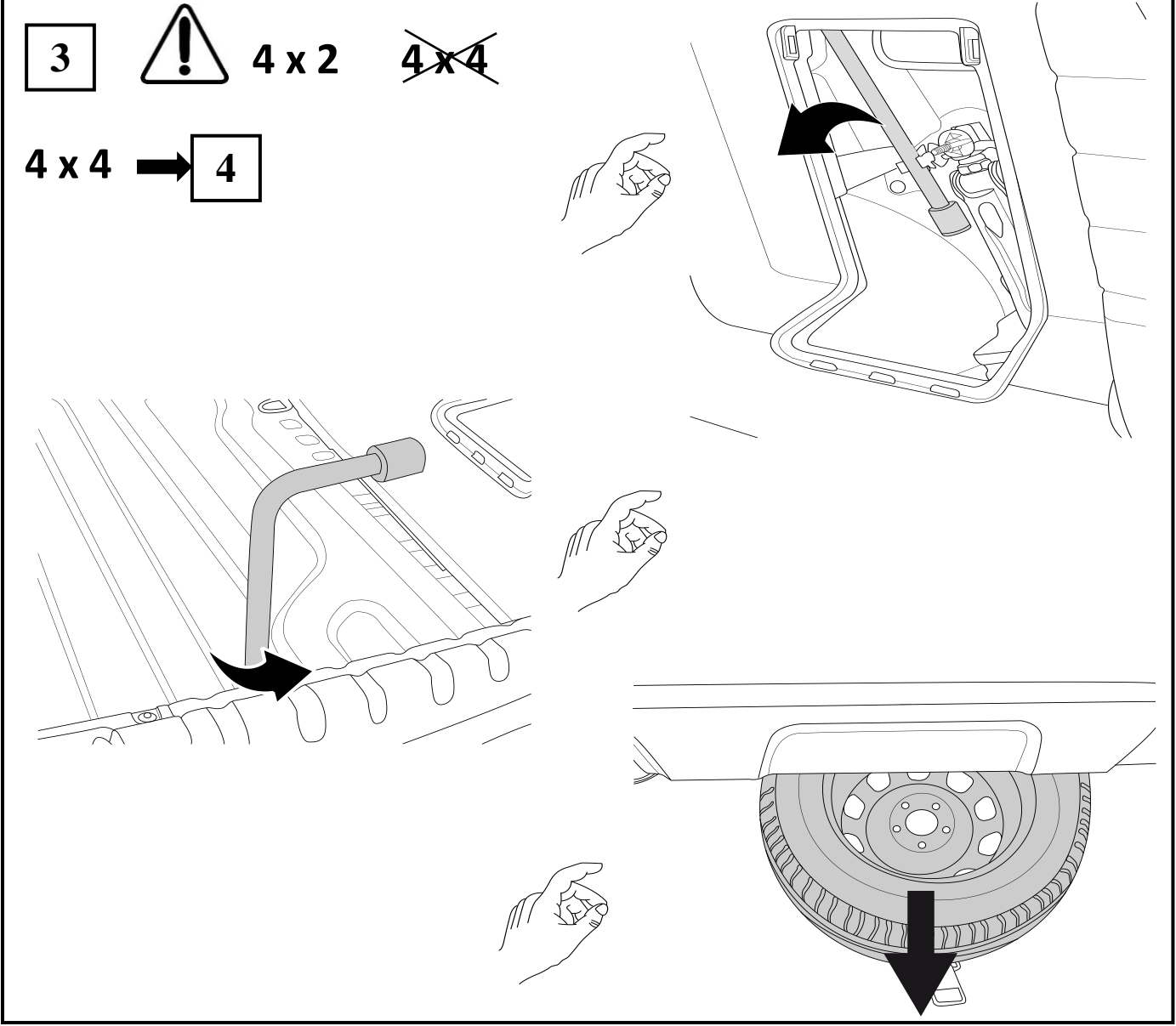
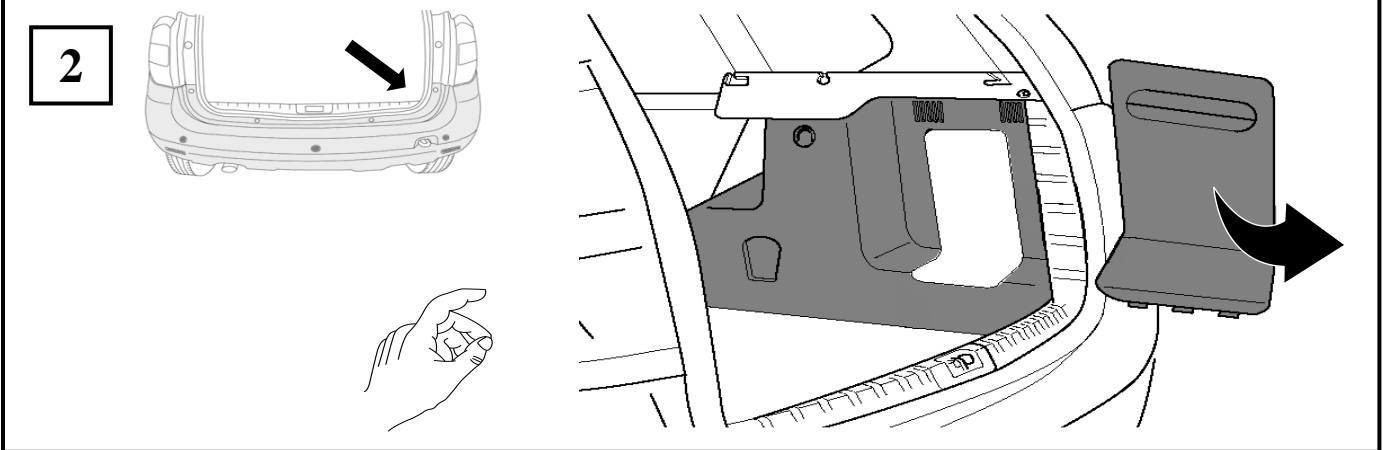
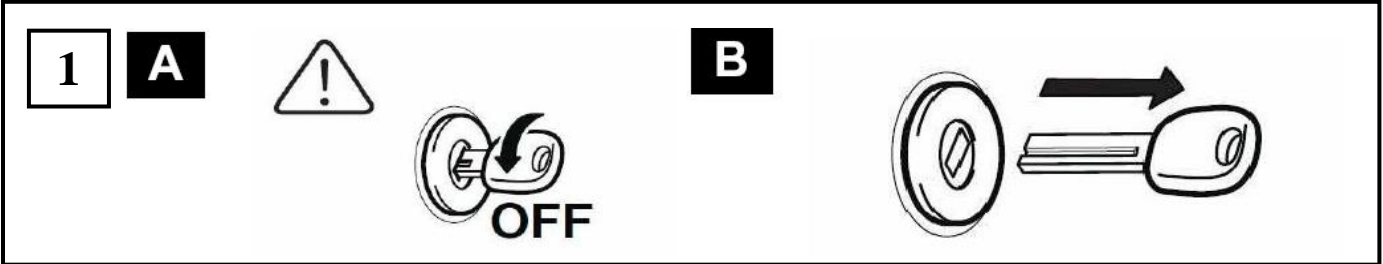

4

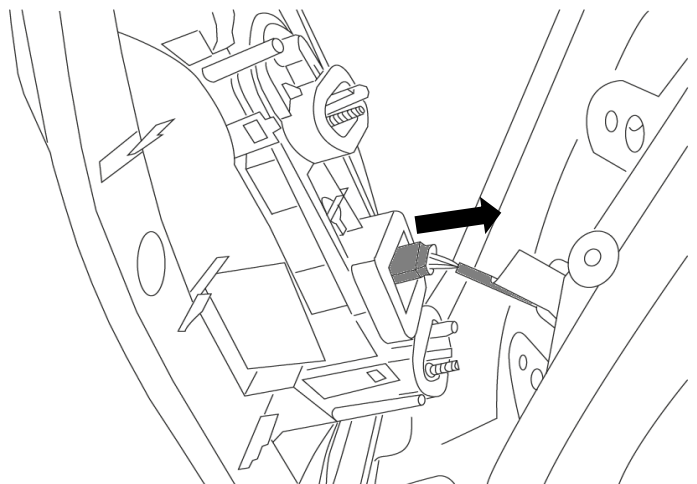
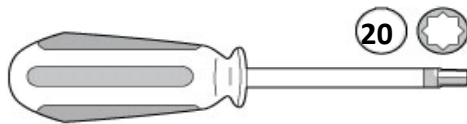
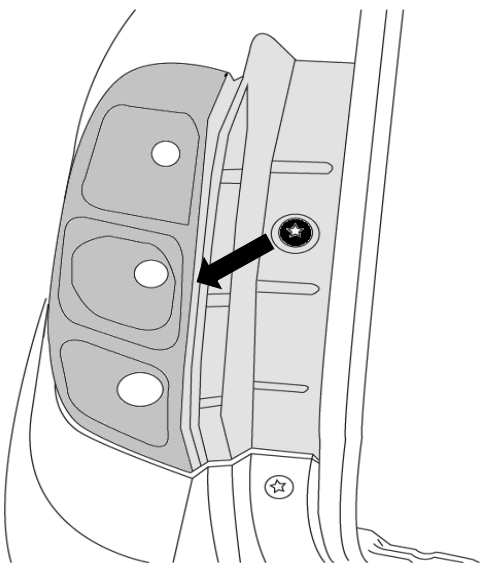
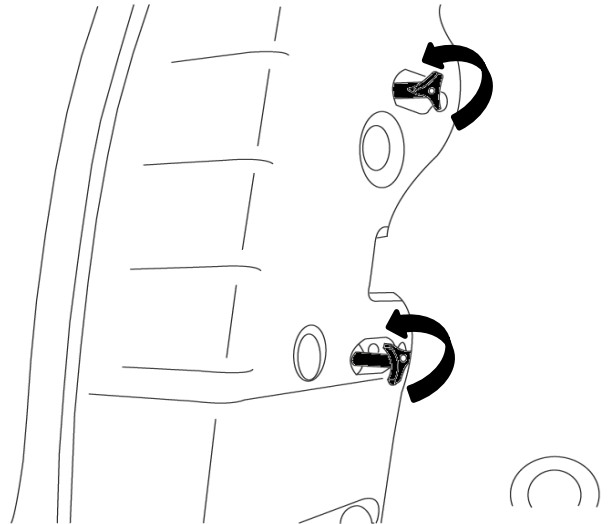
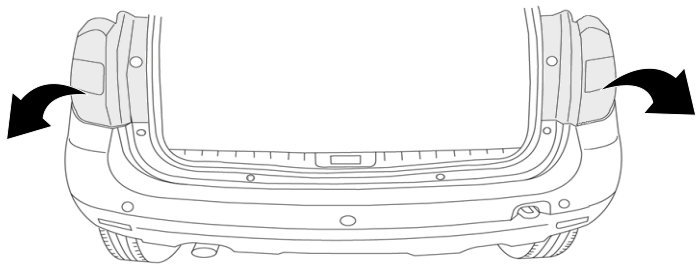

5

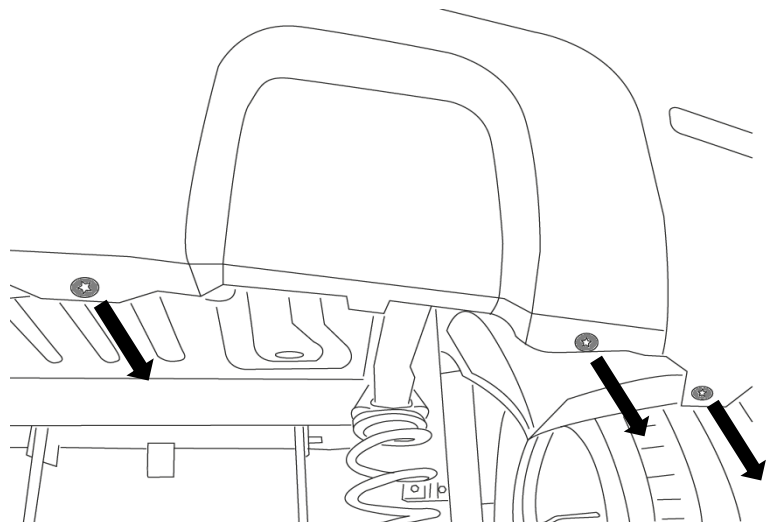
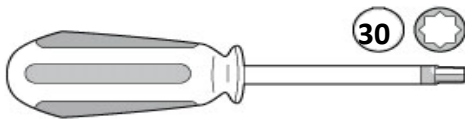
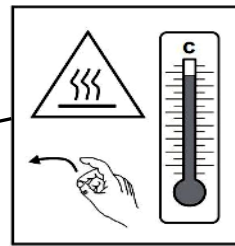
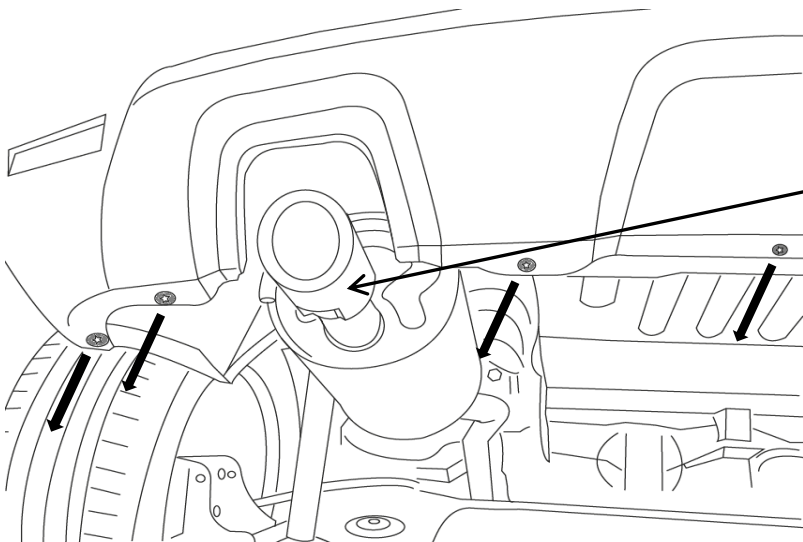
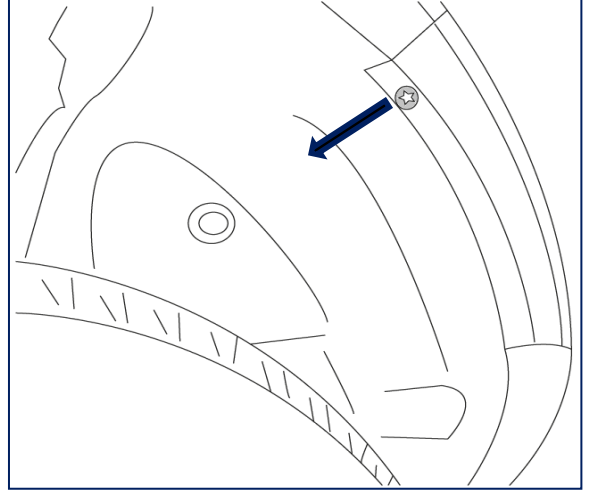
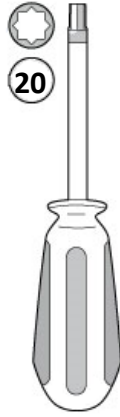
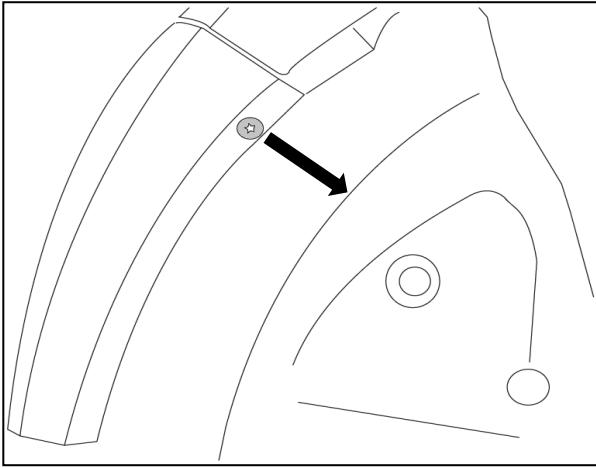
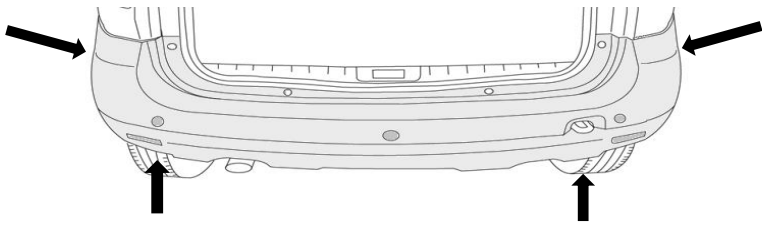

6

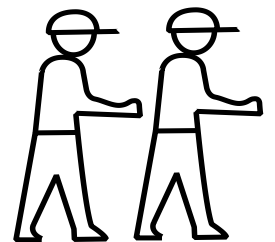
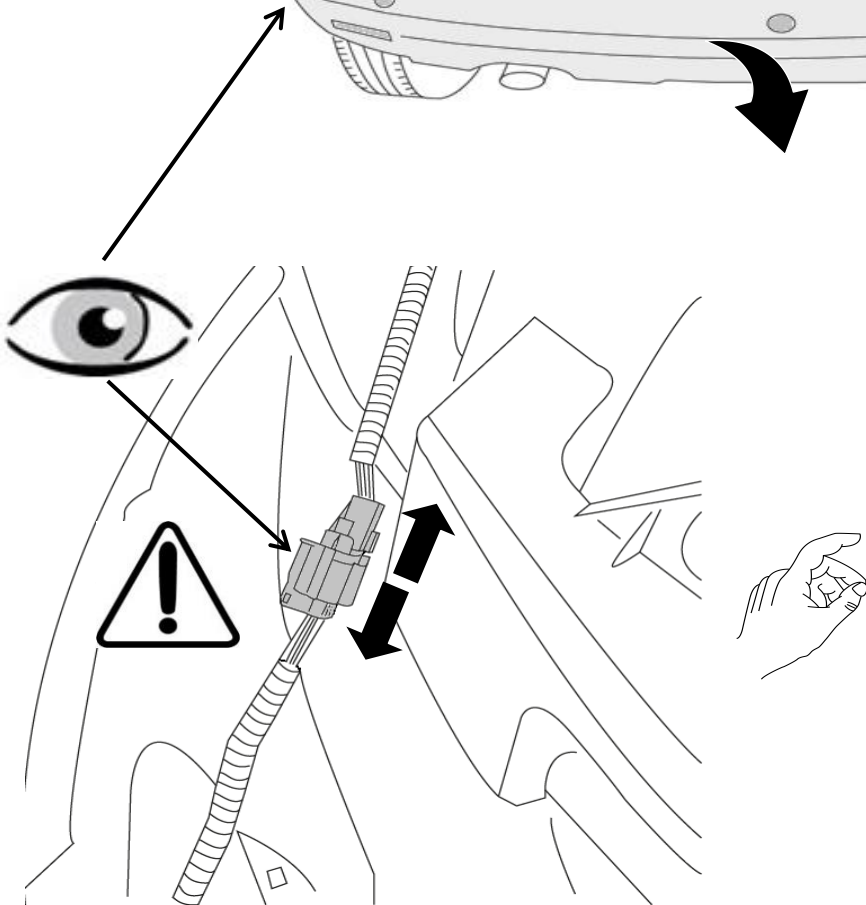
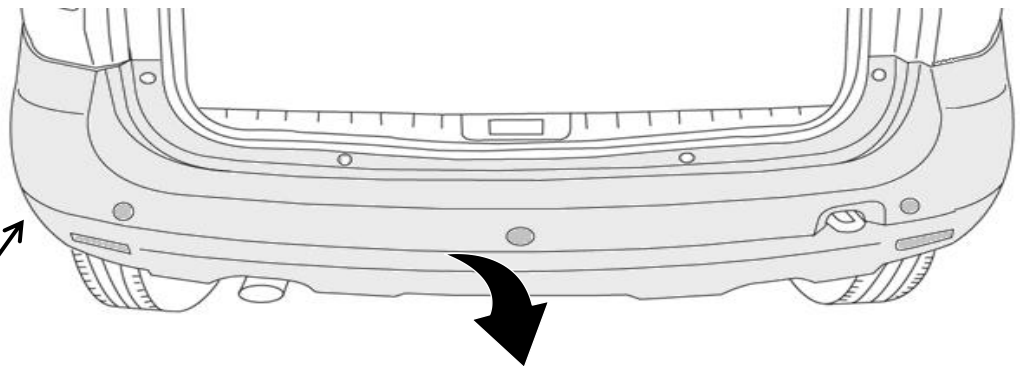
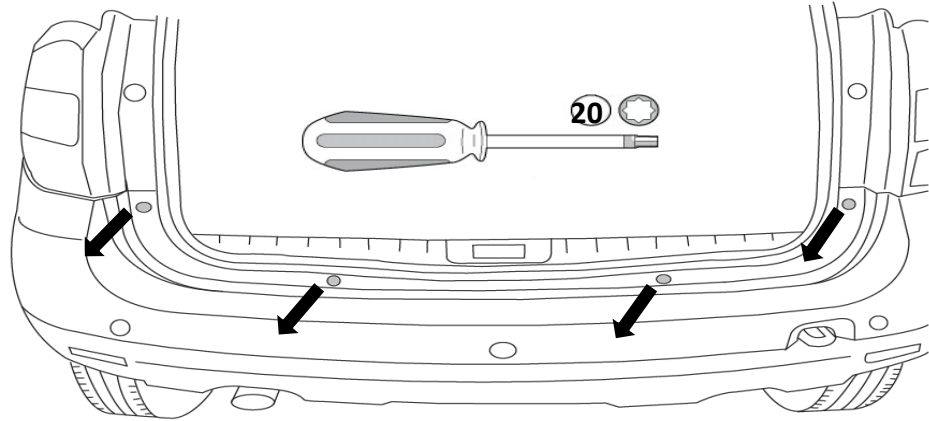
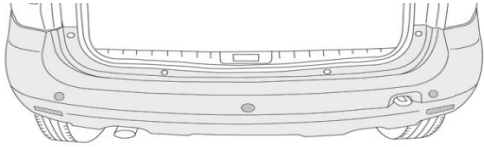

7



4x2

~~4x4~~

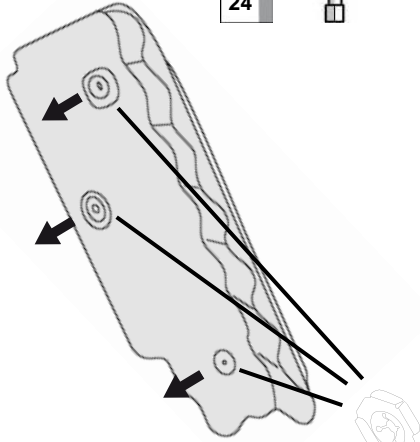
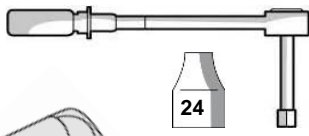
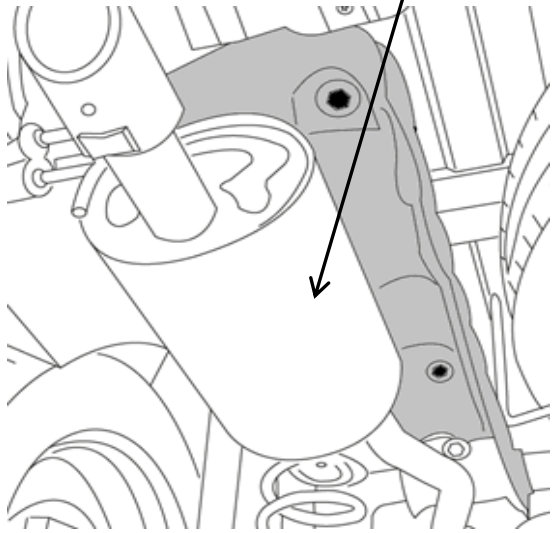
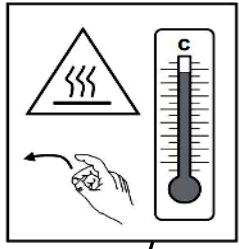
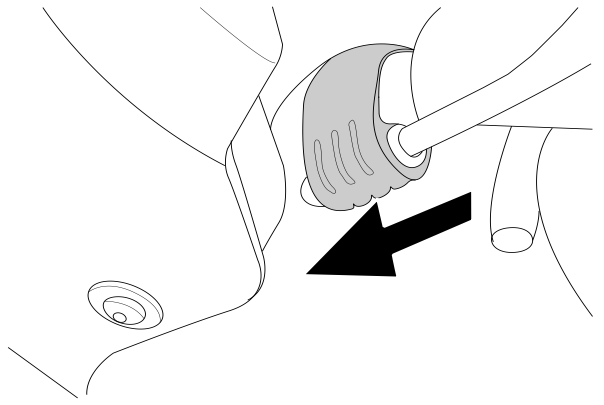

X 3

8

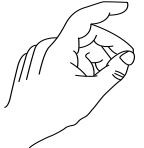
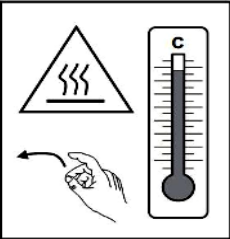
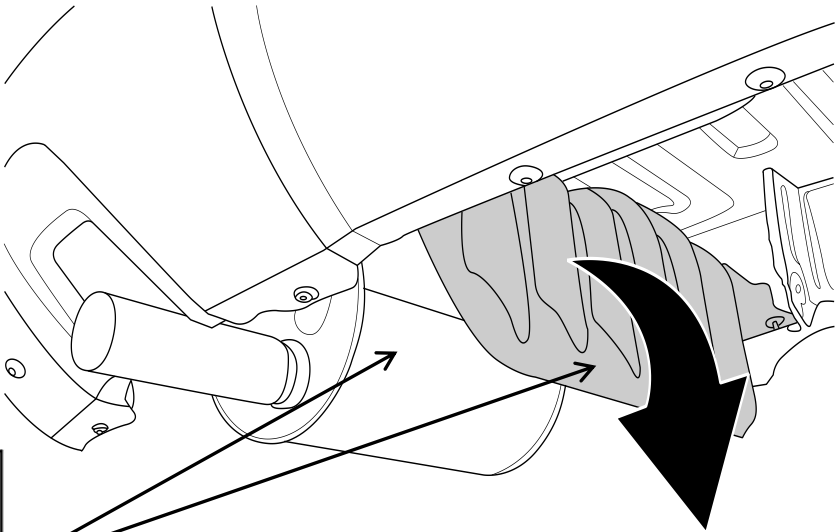

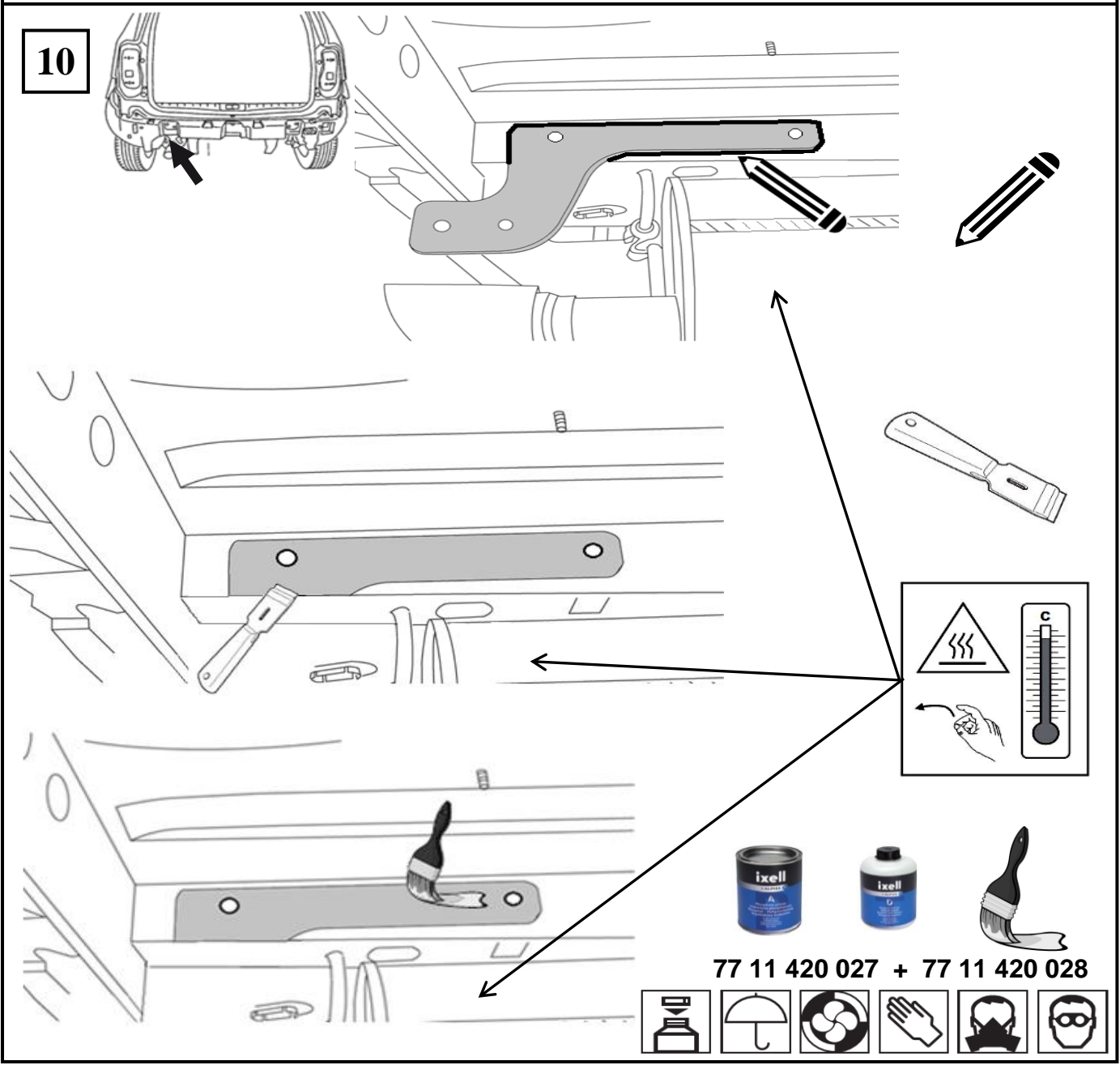
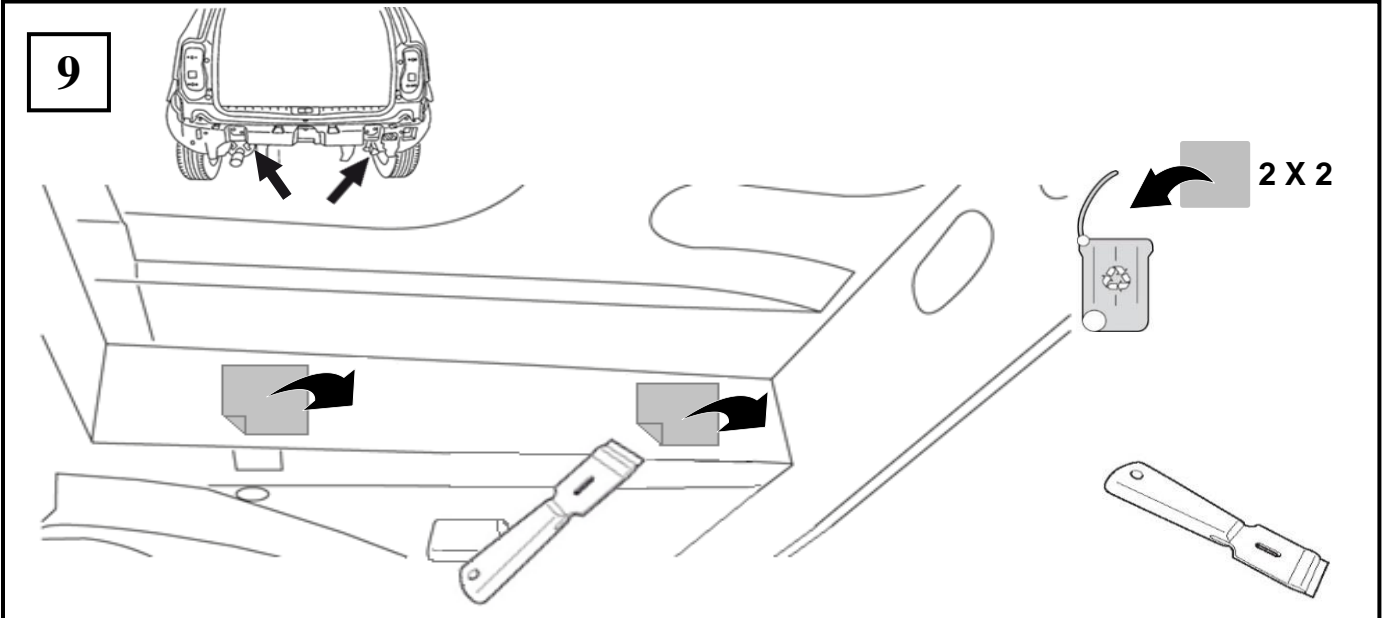

11

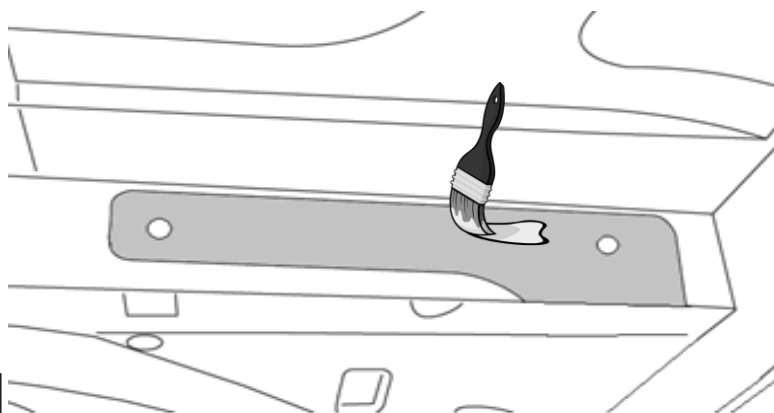
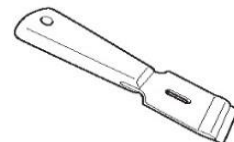
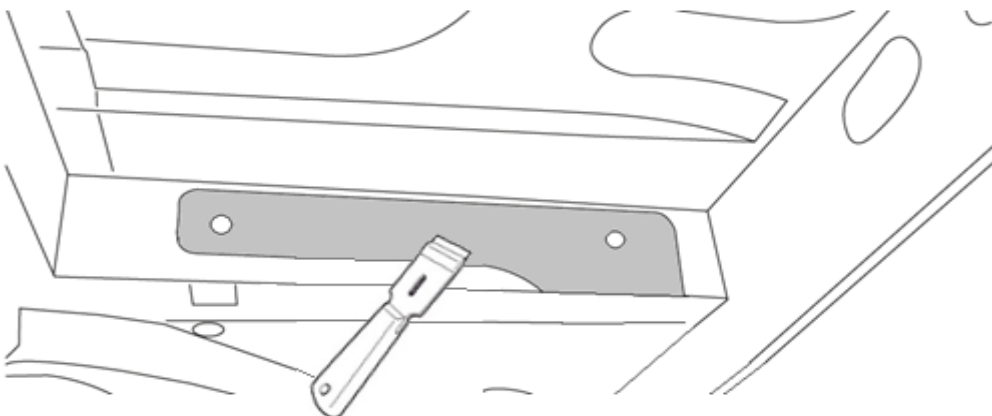
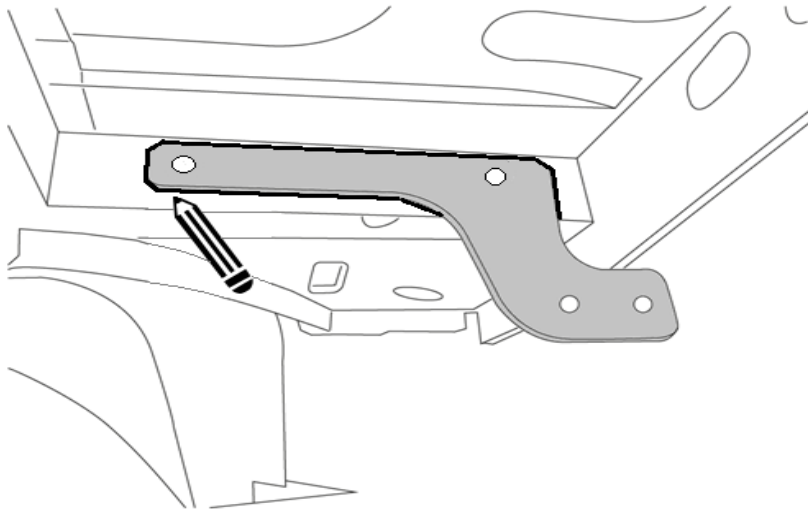
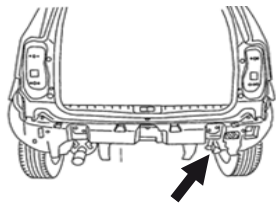

77 11 420 027 + 77 11 420 028



12

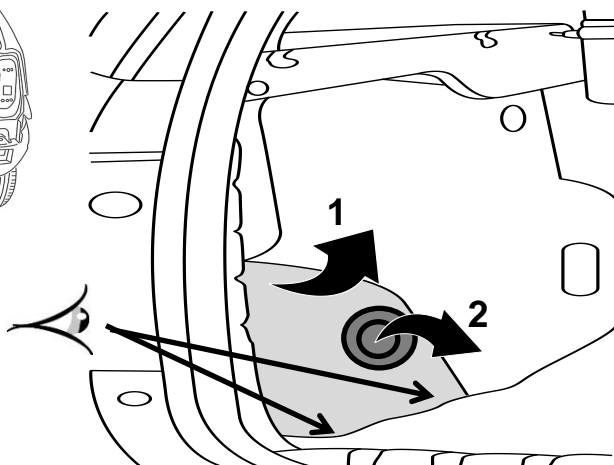
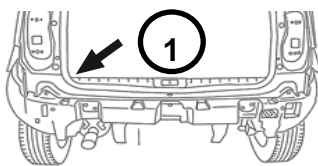
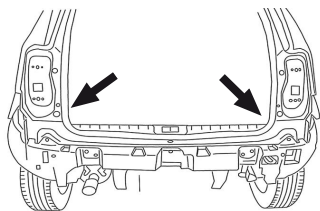

x 2



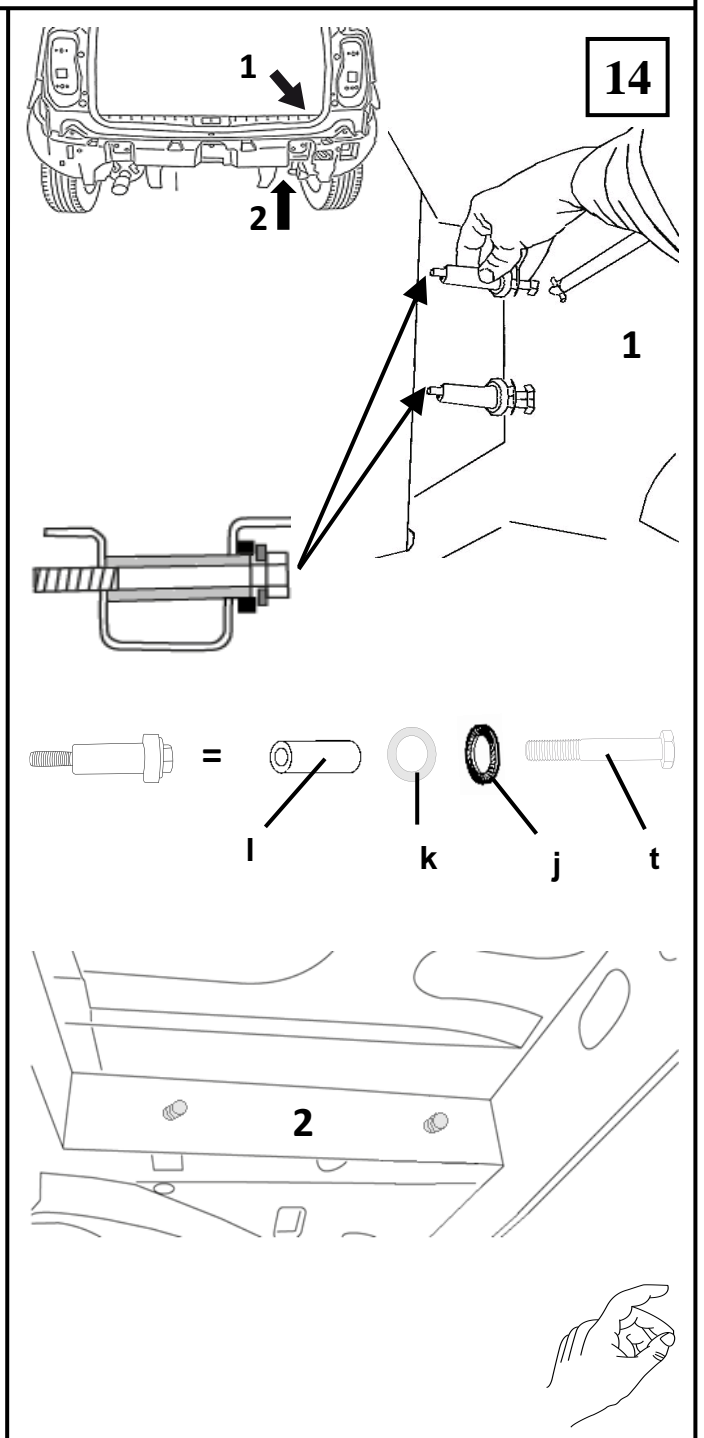
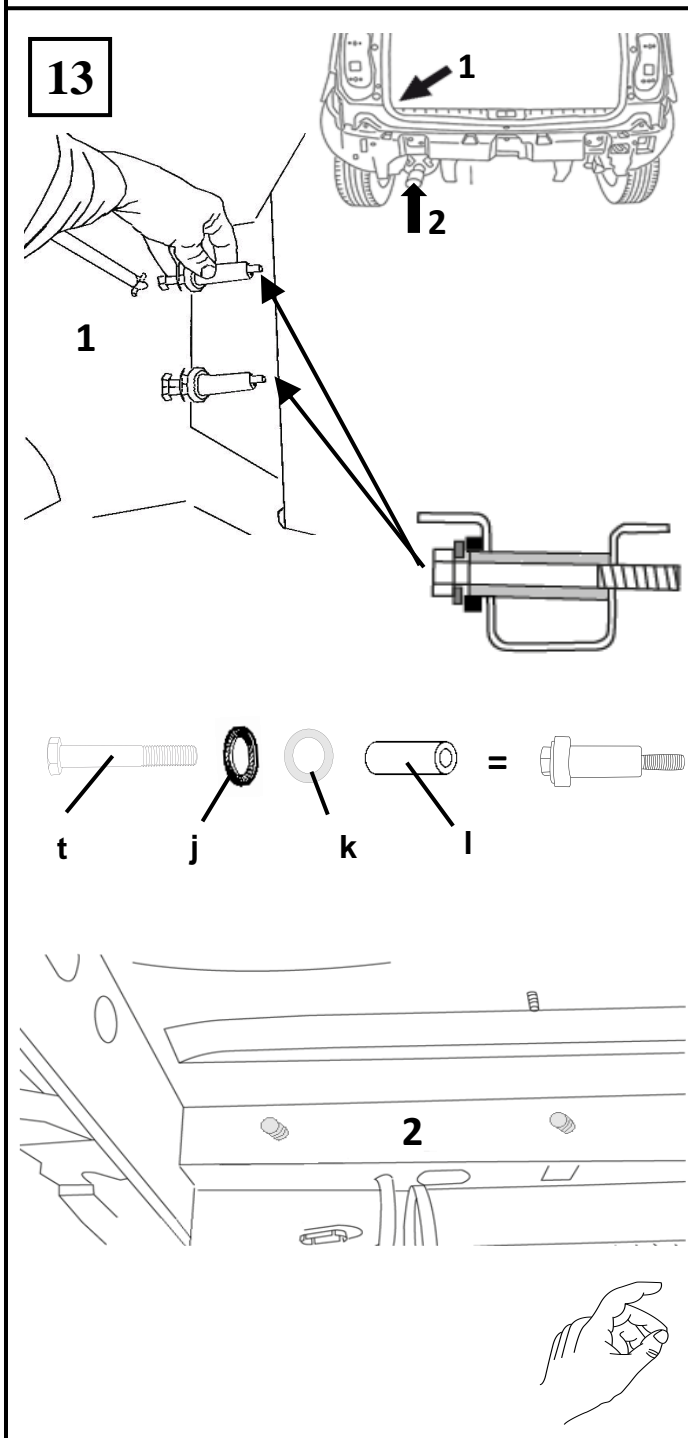
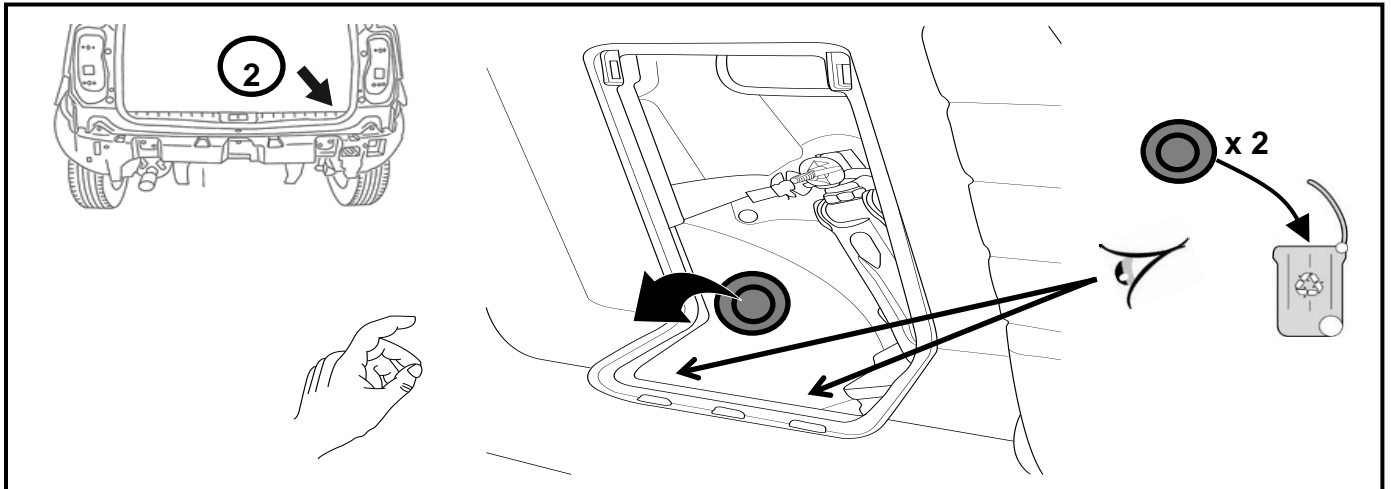

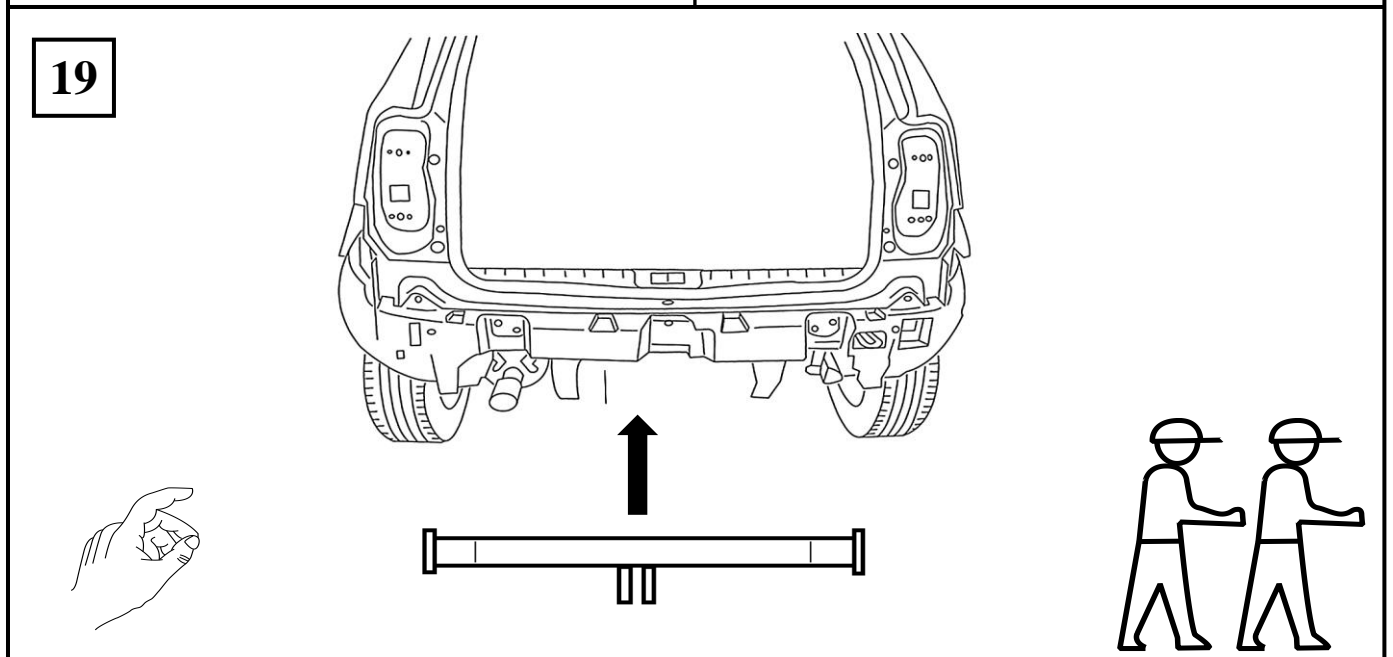
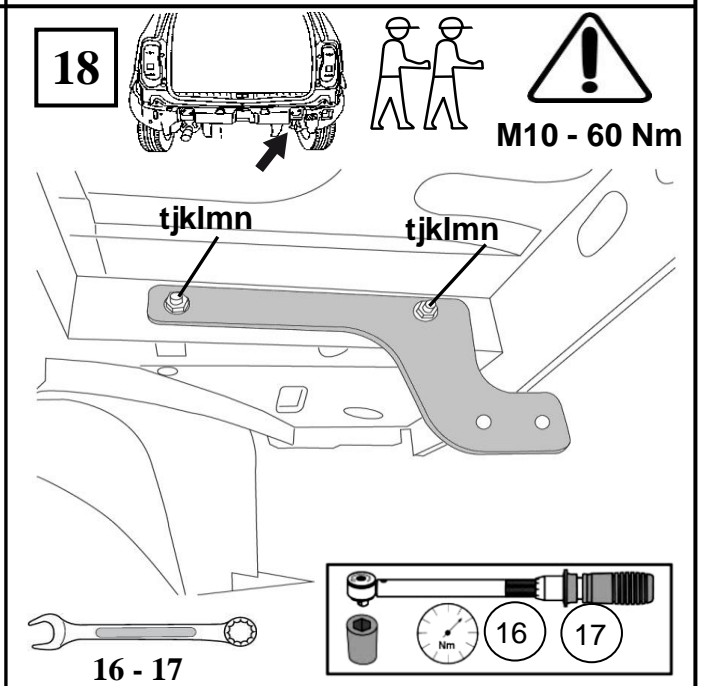
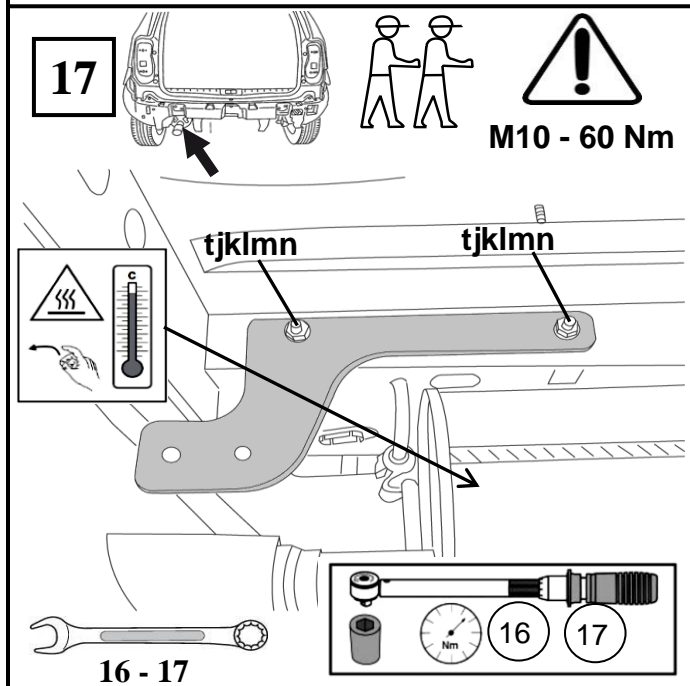
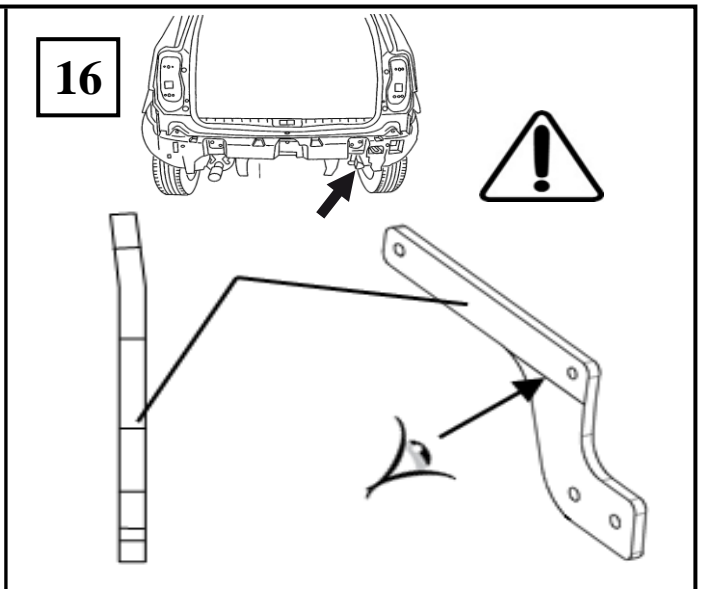
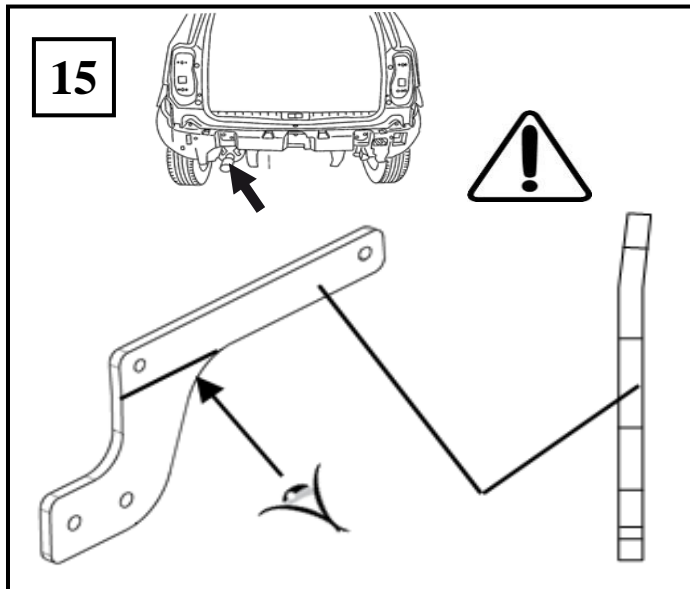

20

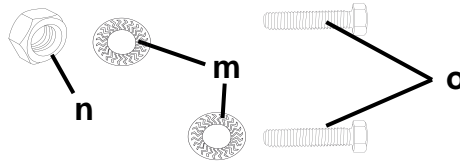
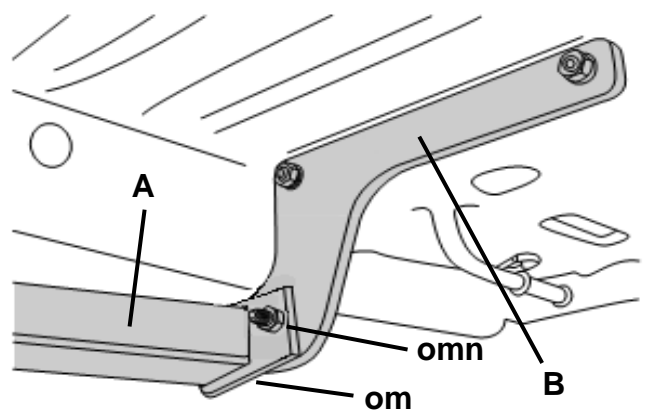
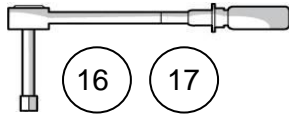
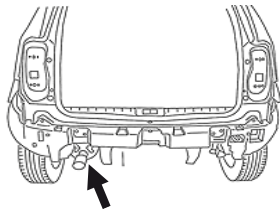

21

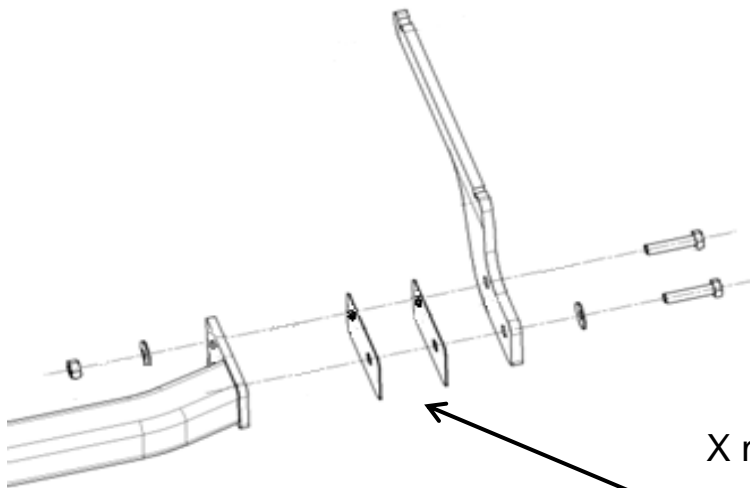
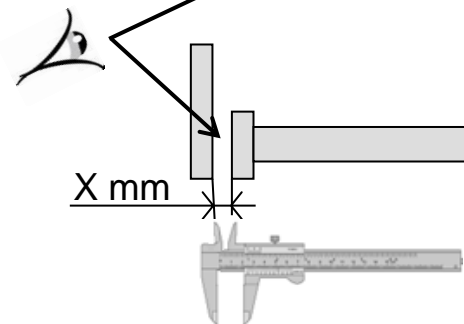
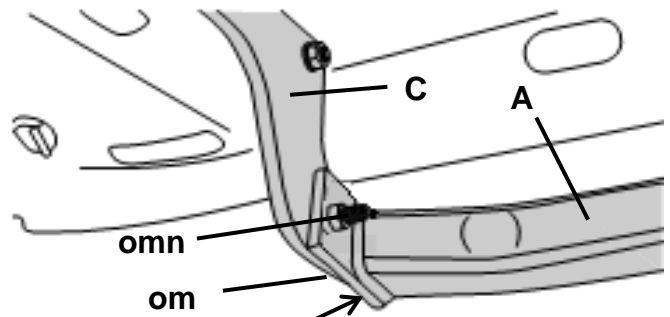
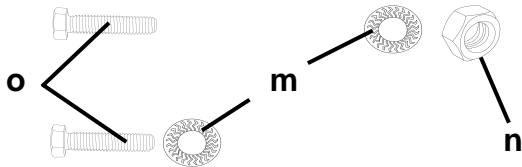
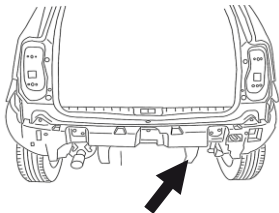

X mm = Y mm

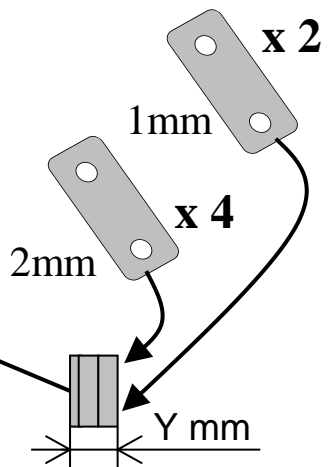

22

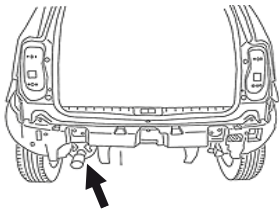

M10 - 60 Nm

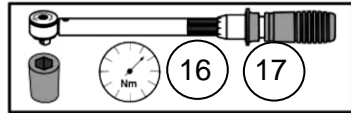
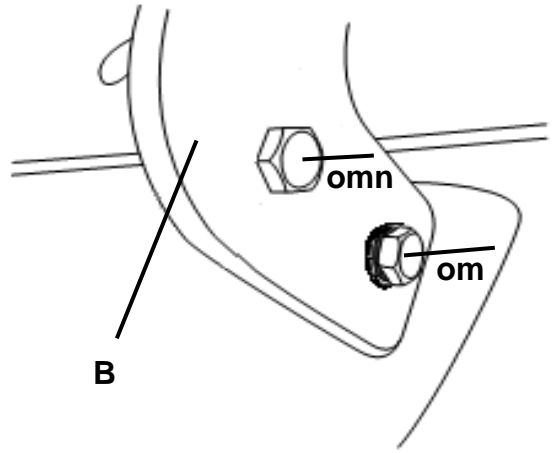

23

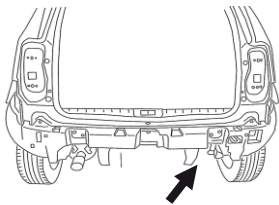

M10 - 60 Nm

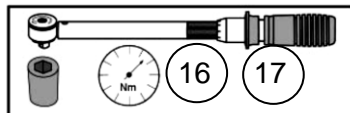
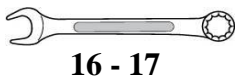
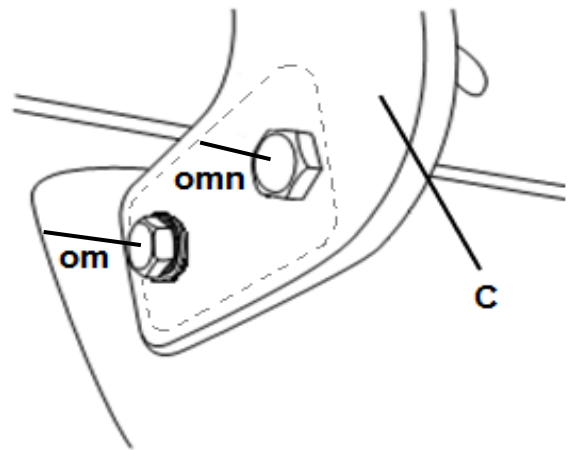

24



4 x 2

~~4 x 4~~

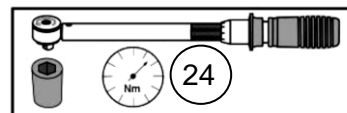
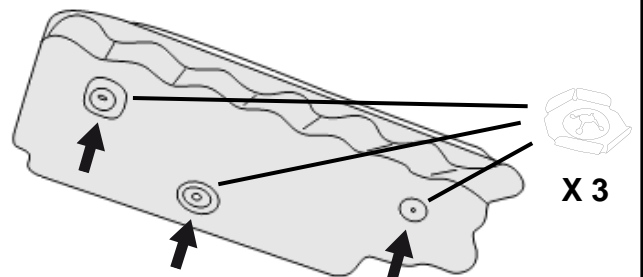
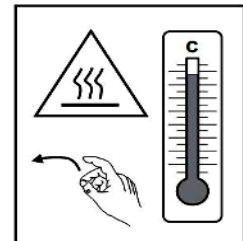
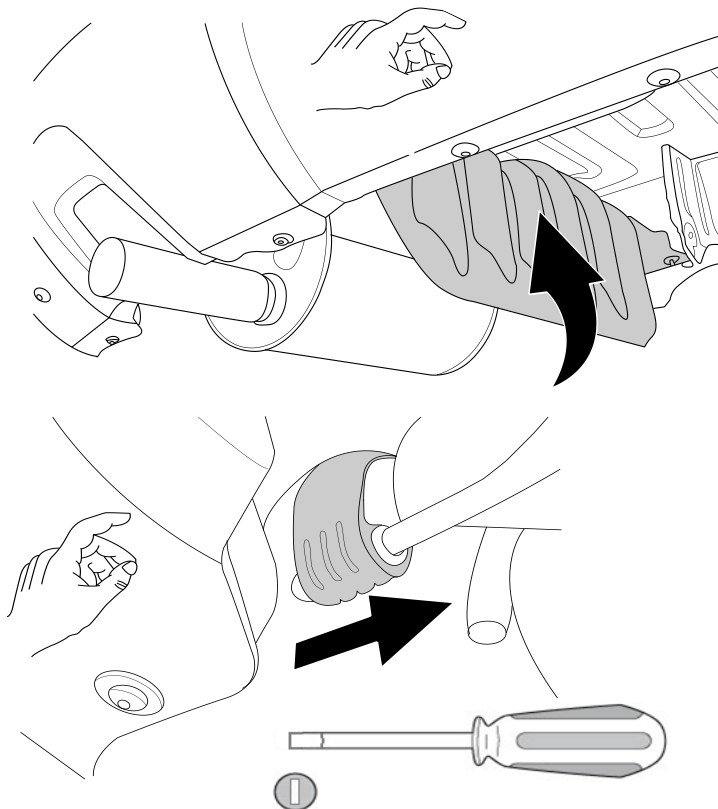

25



4 x 2

~~4 x 4~~

4 x 4

26

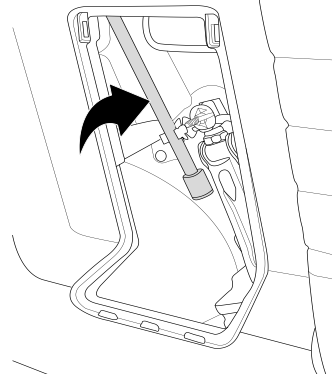
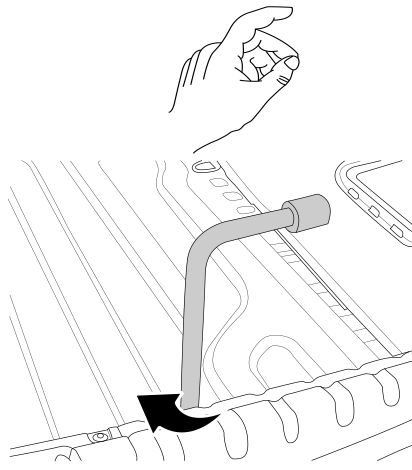
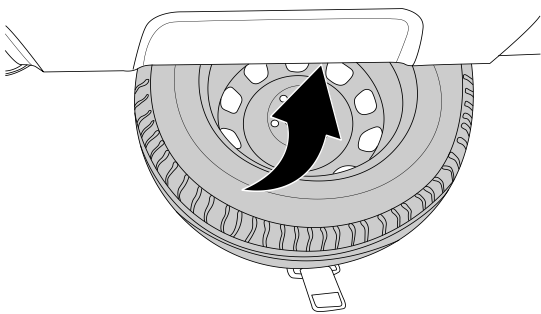

26

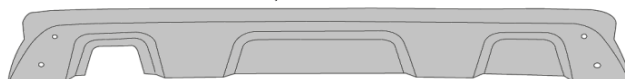
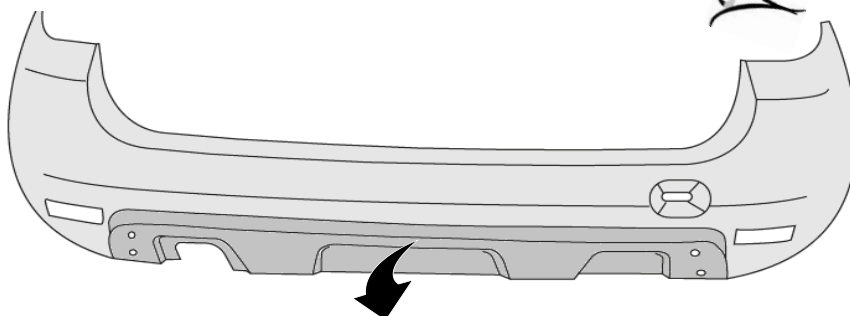
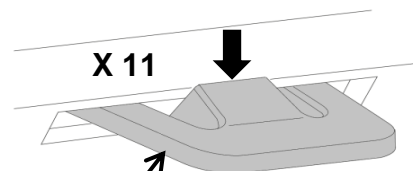
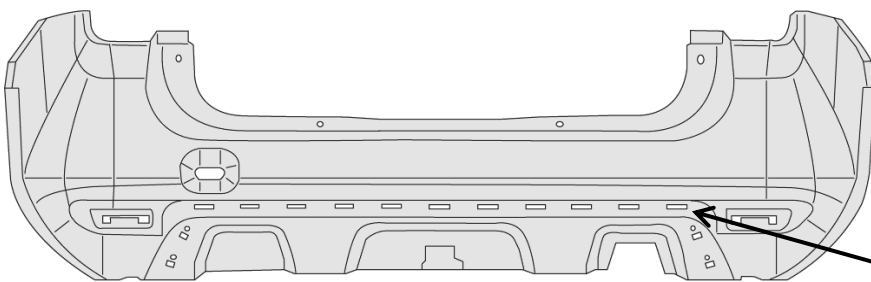
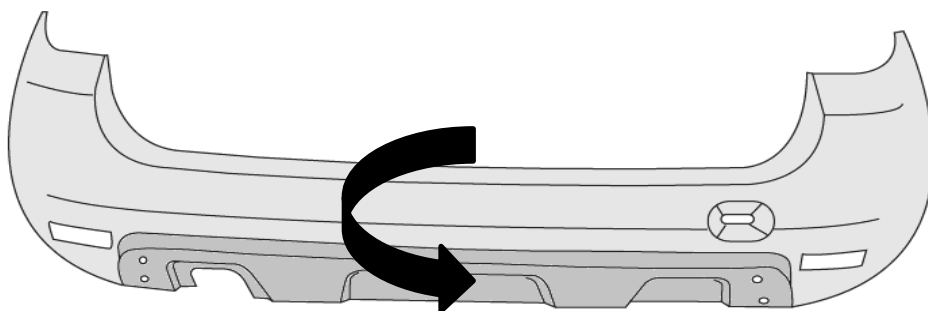
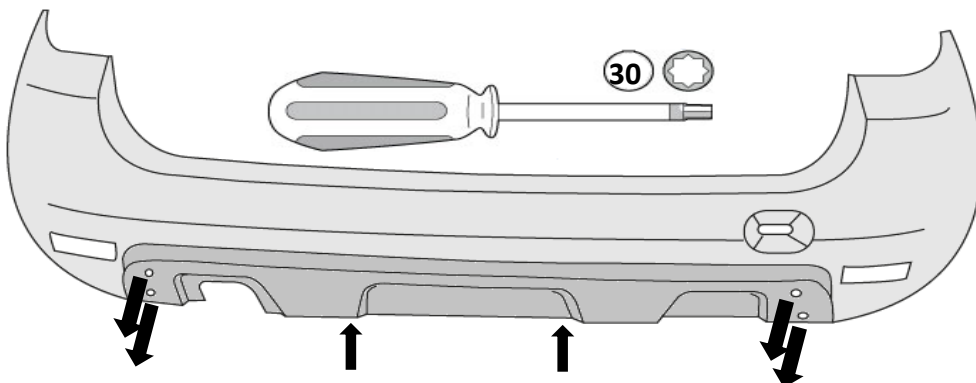
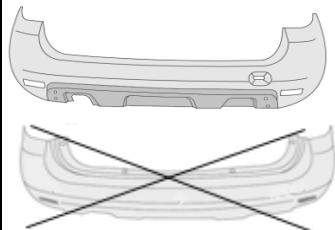

27

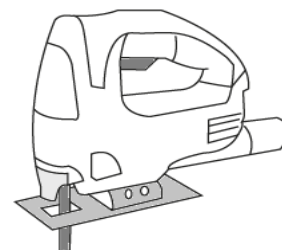
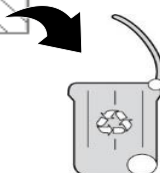
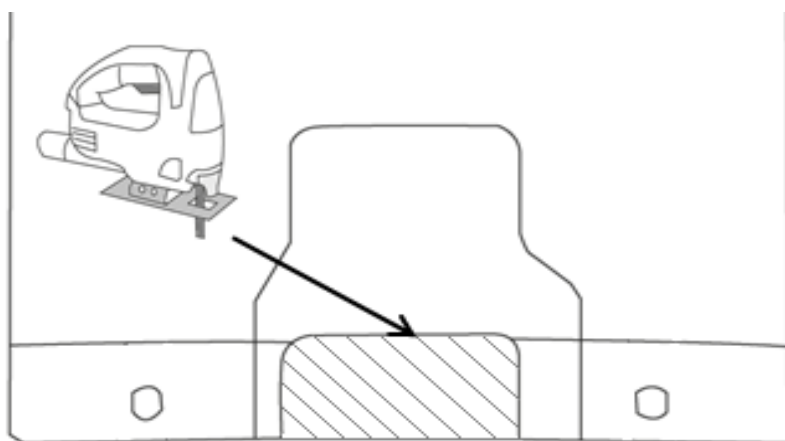
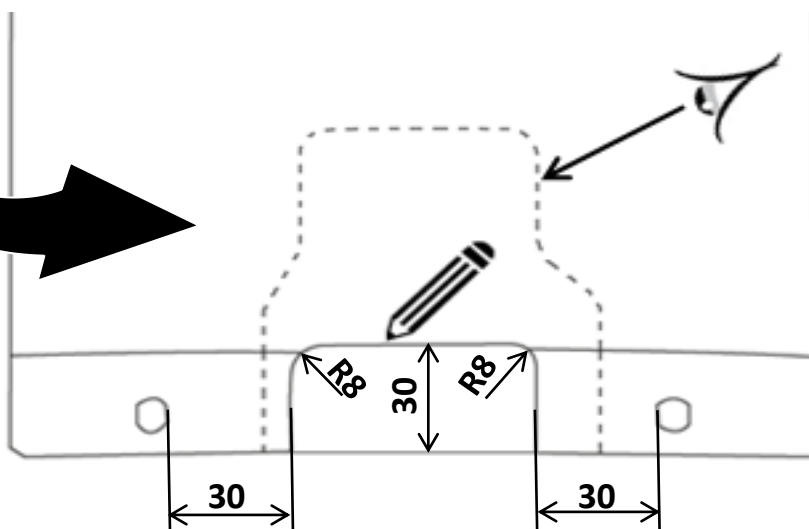
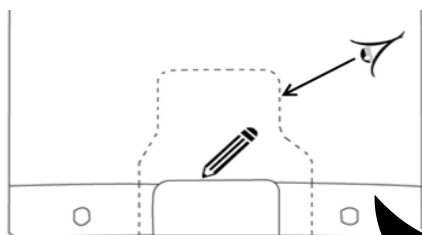
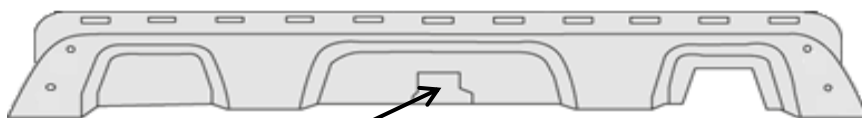
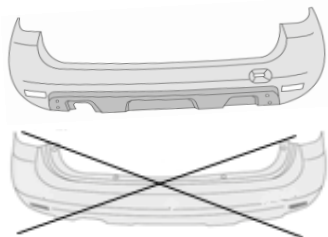

28

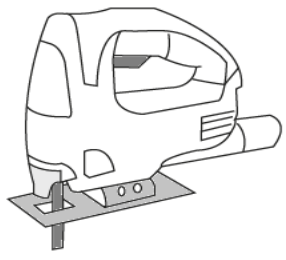
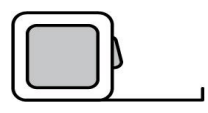
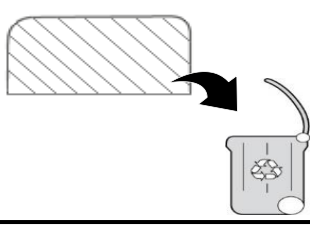
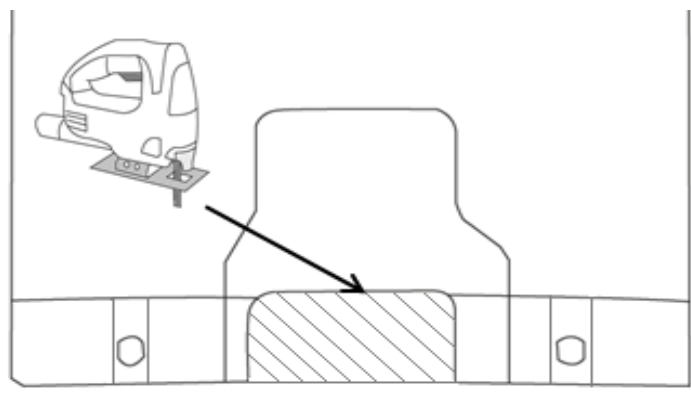
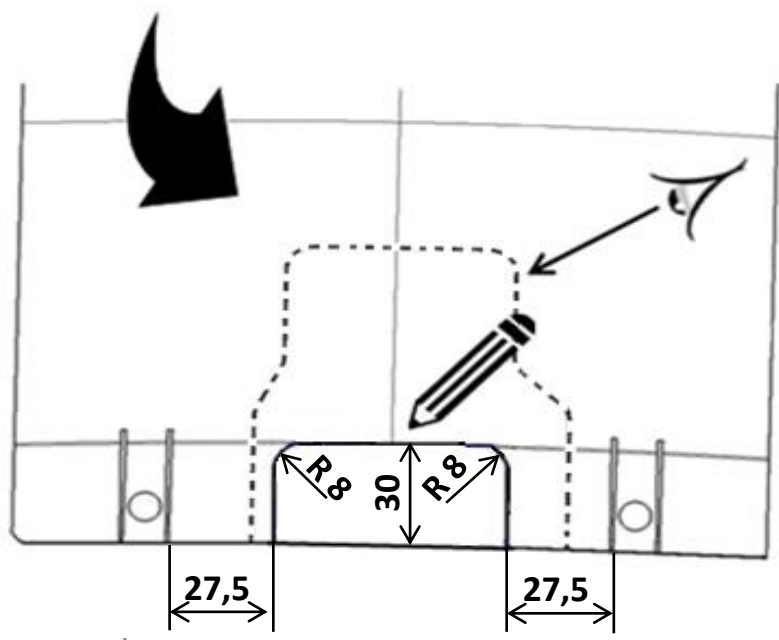
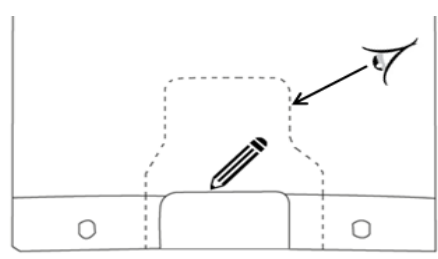
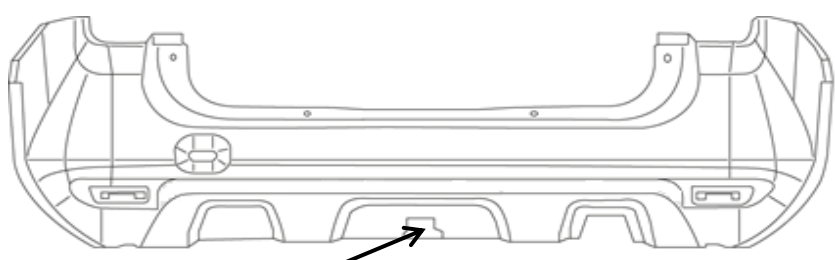
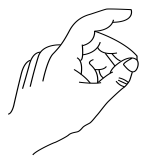
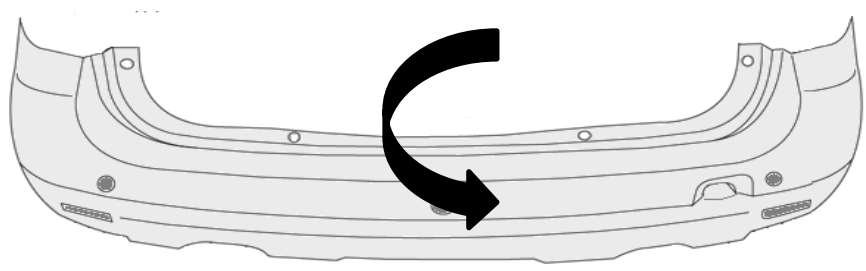
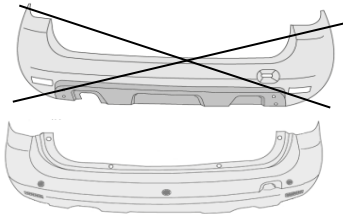

29

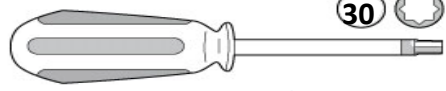
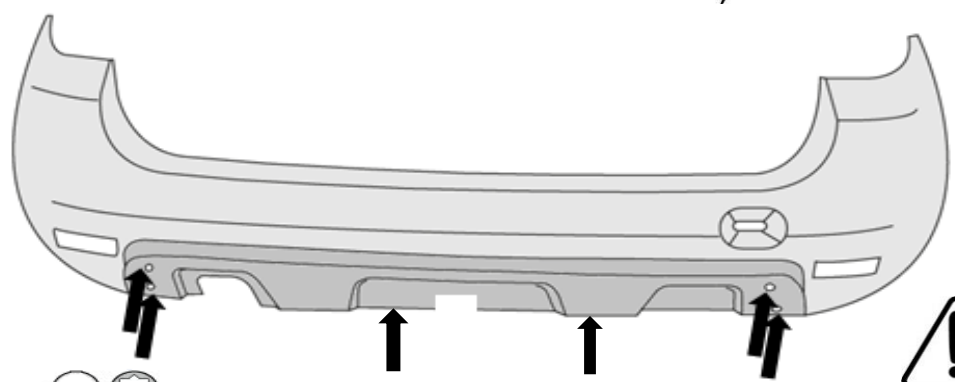
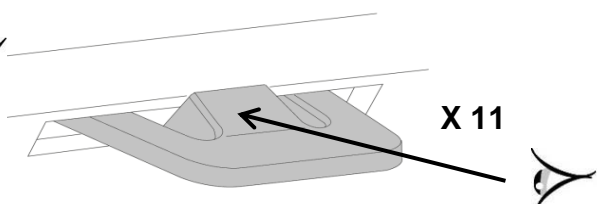
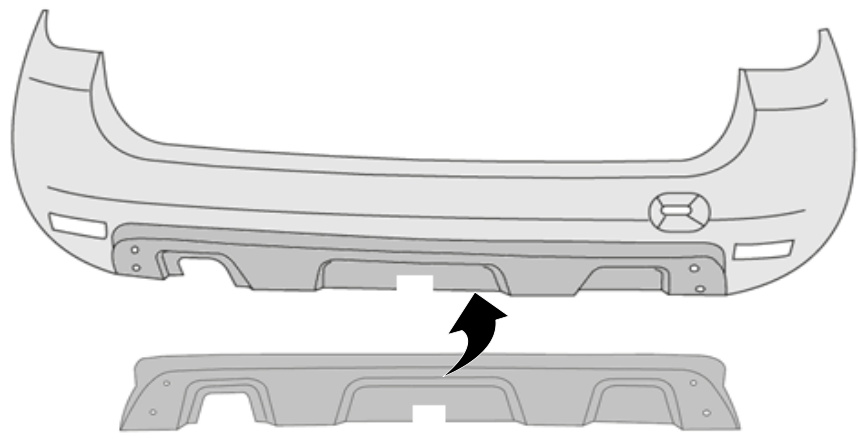
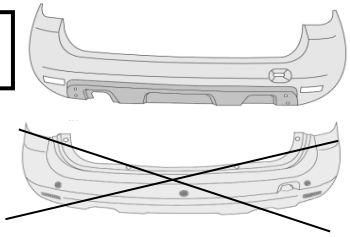

30

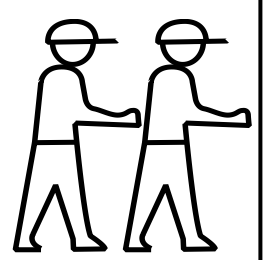
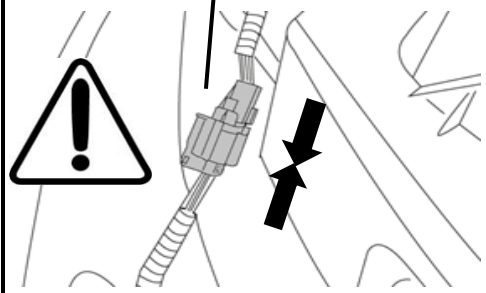
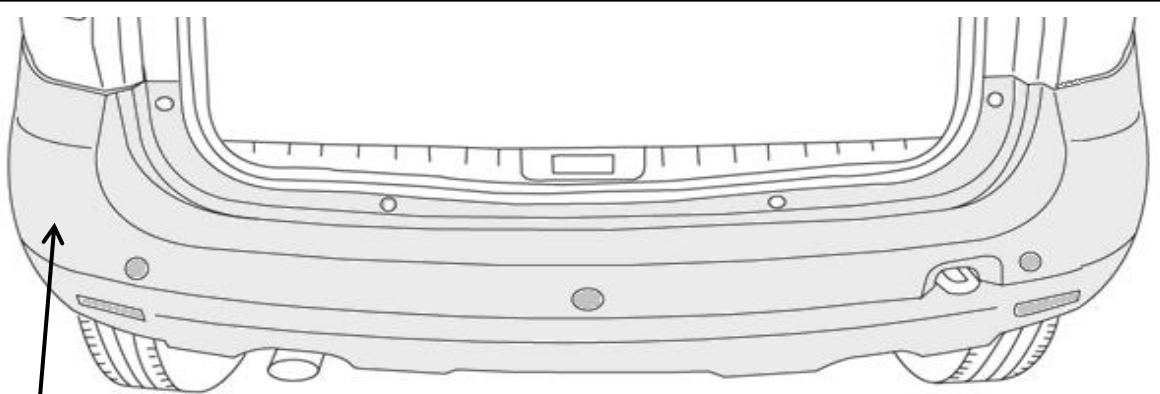

31

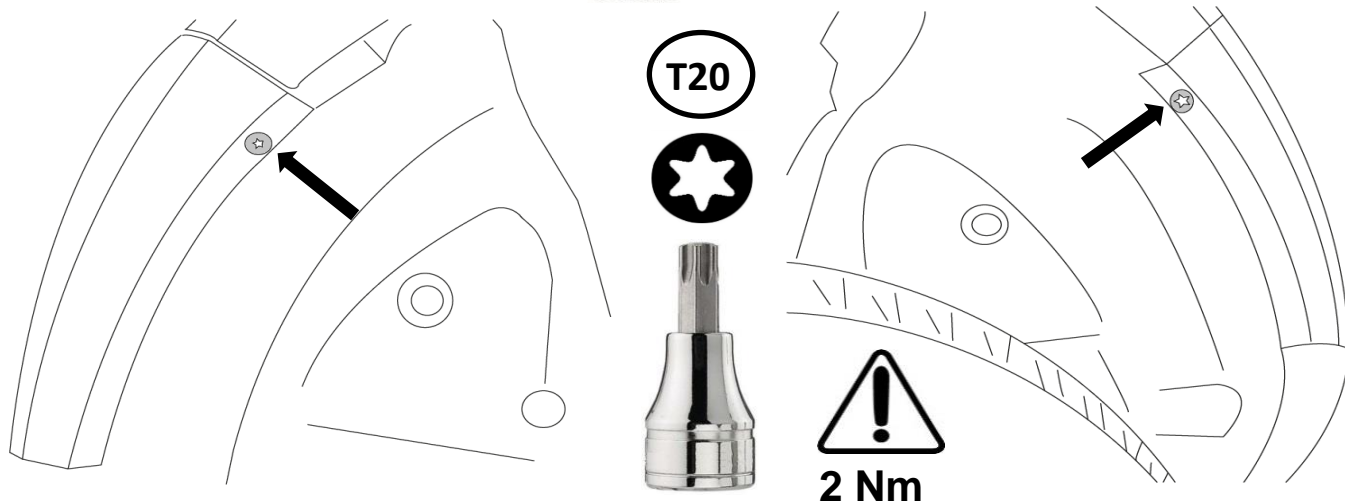
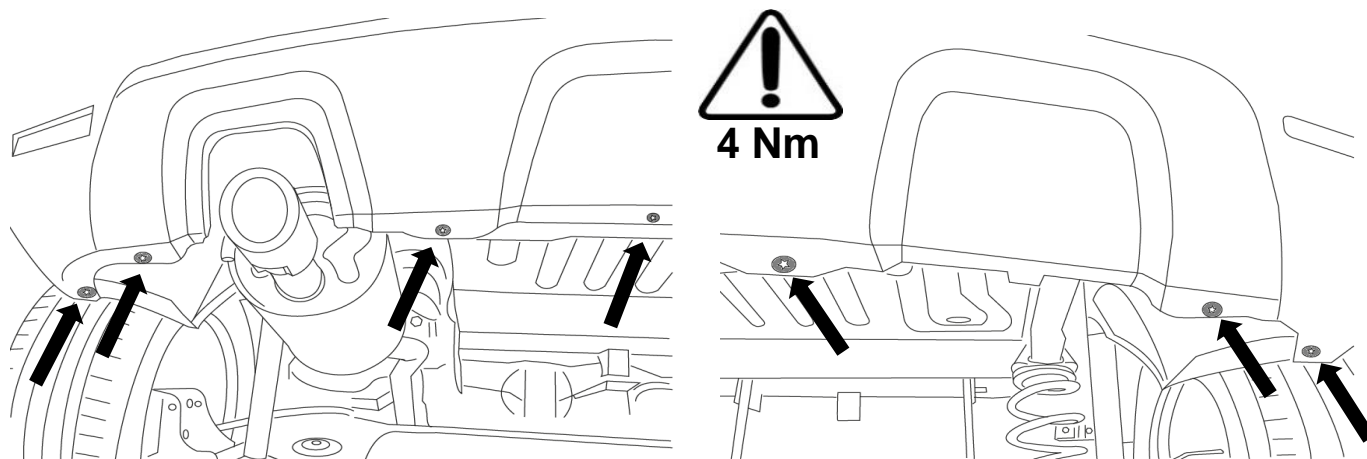
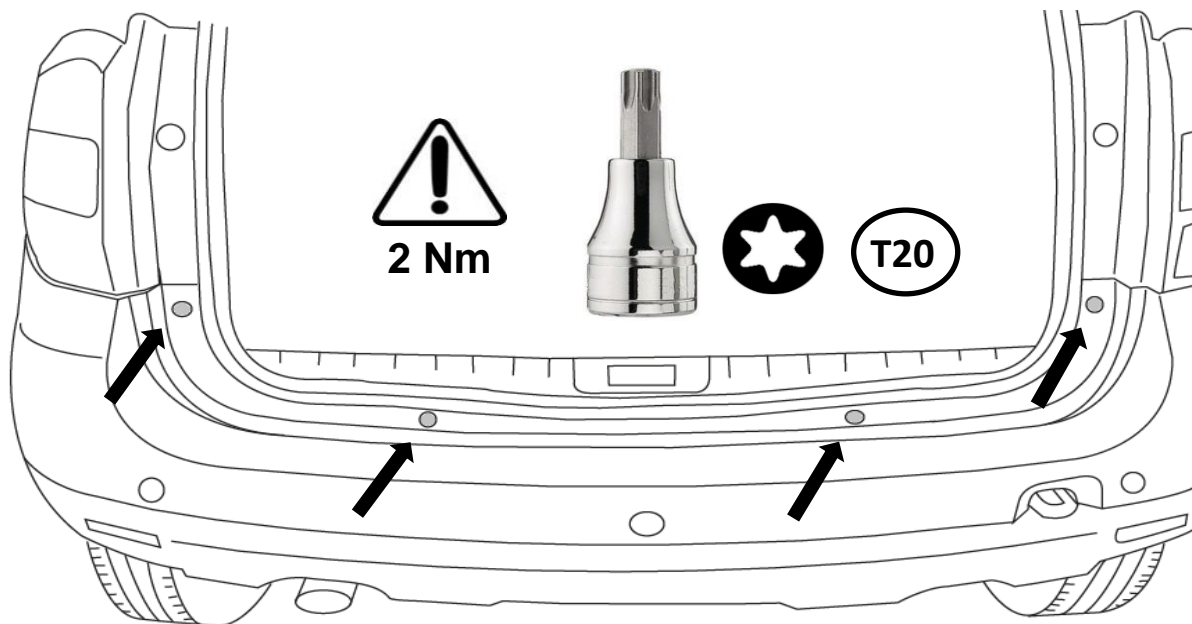
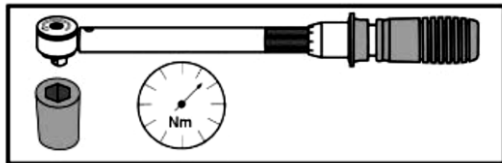

32

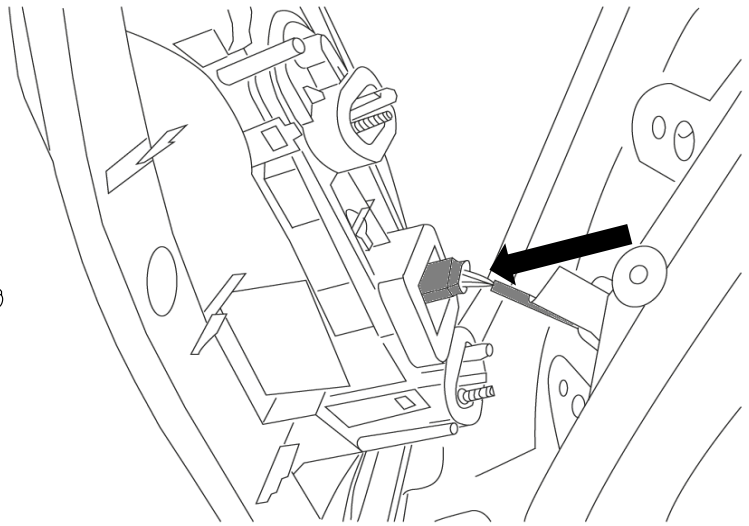
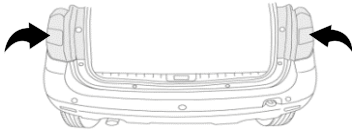

2 Nm

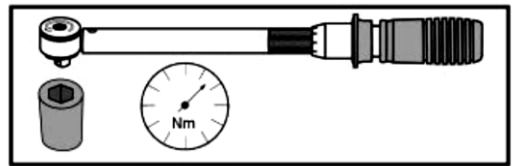
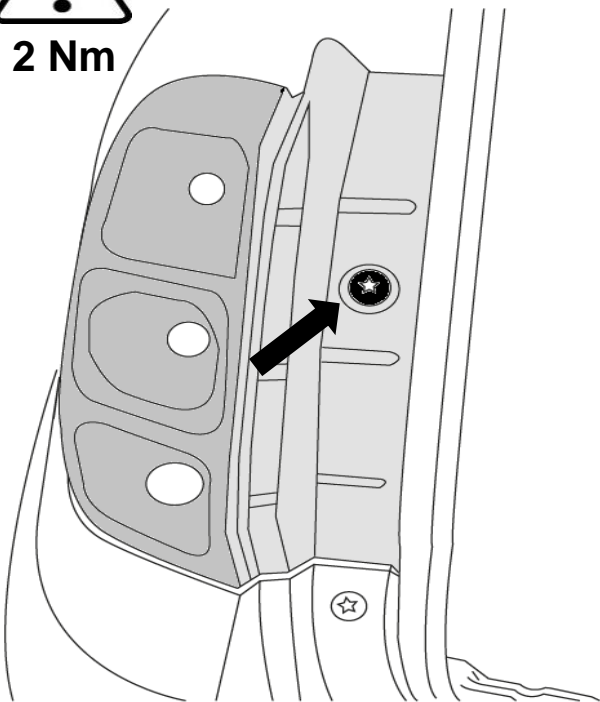

T20

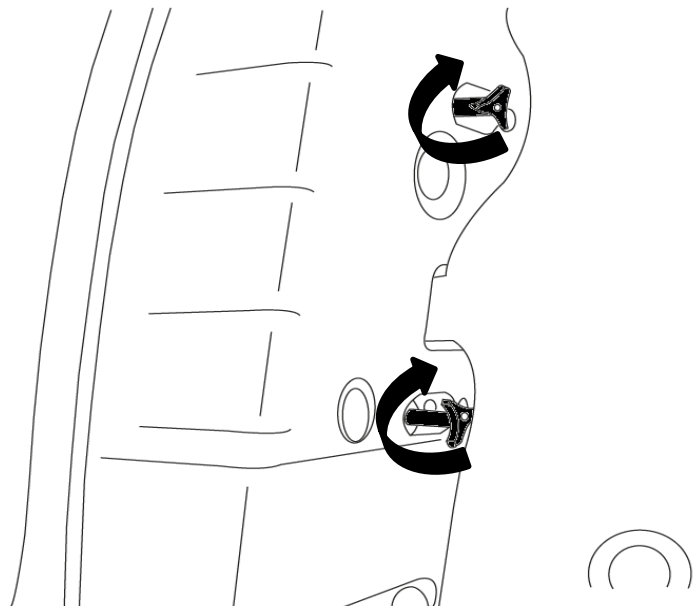

33

82 01 271 007

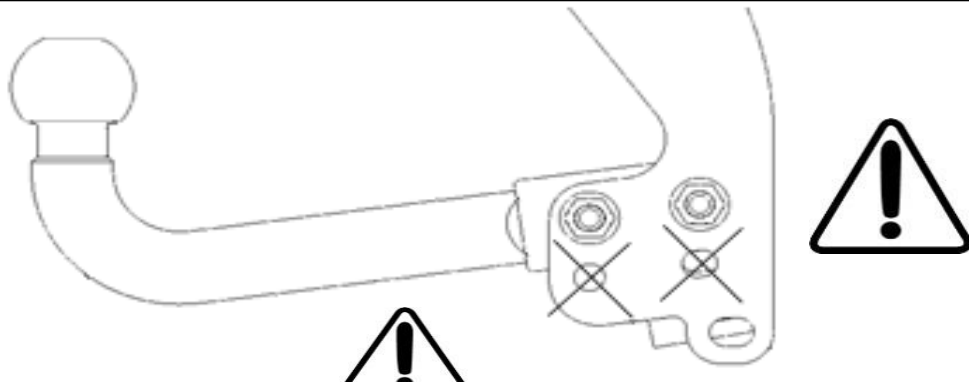
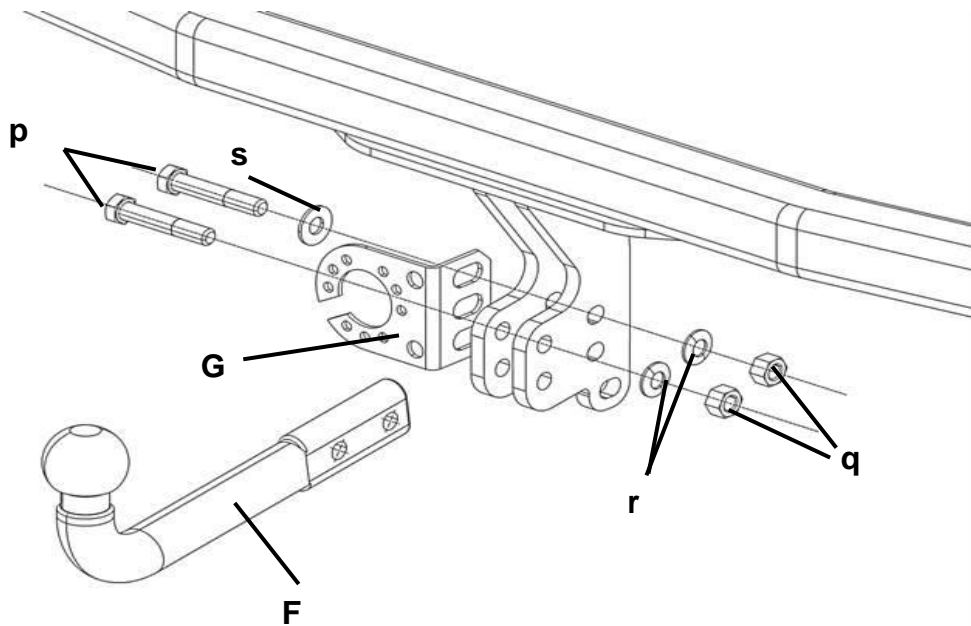

M12 CI 10.9 100 Nm

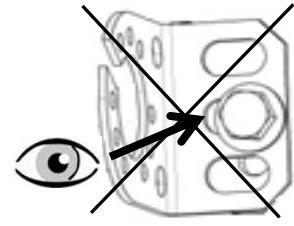
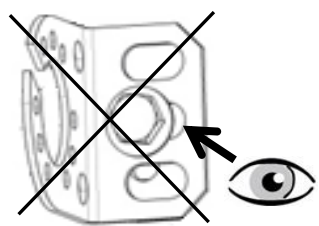
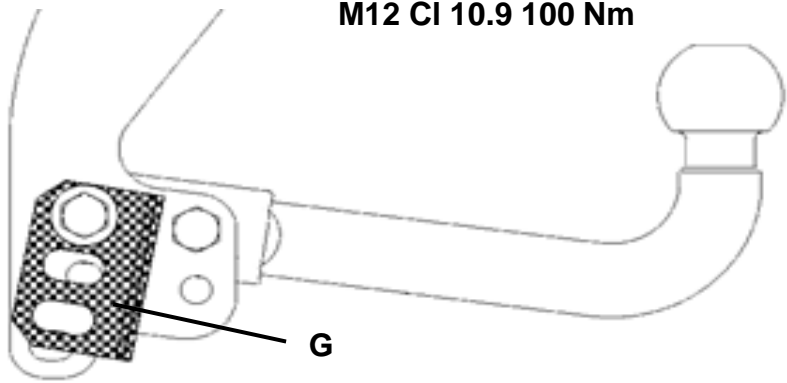

18 - 19

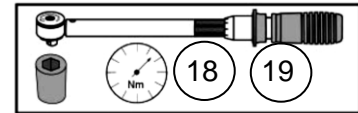

34

82 01 536 476

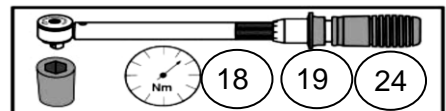
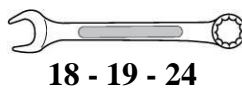
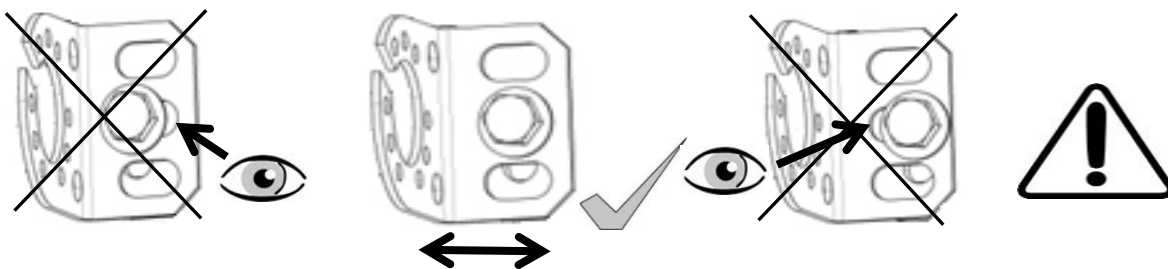
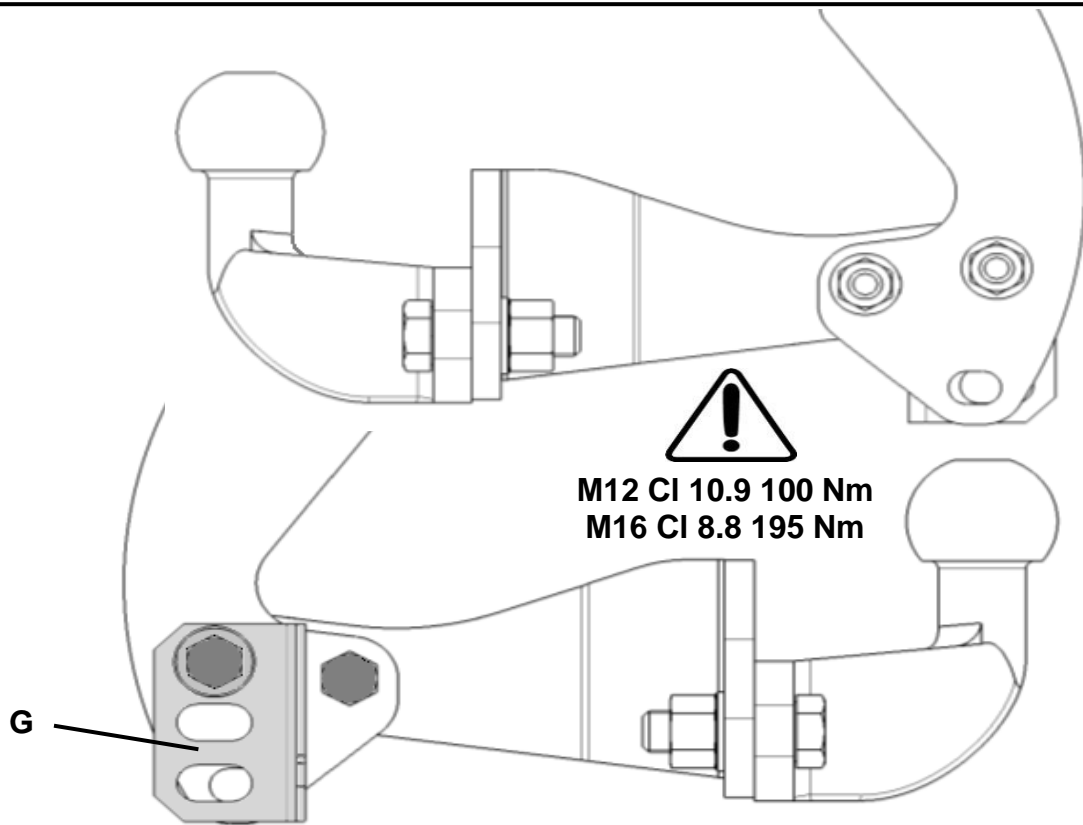
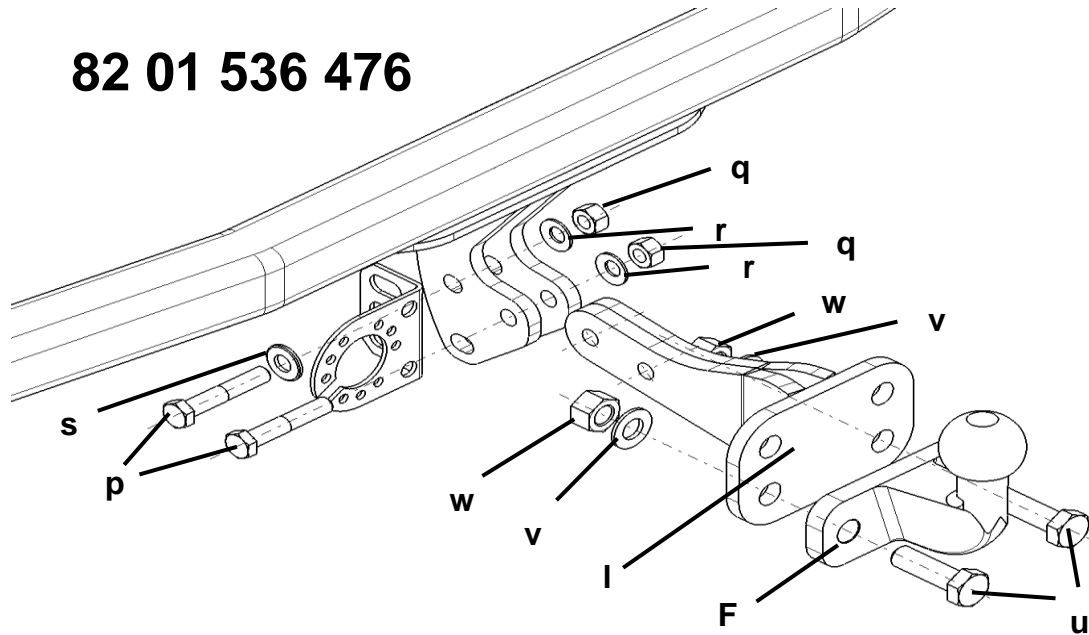

35

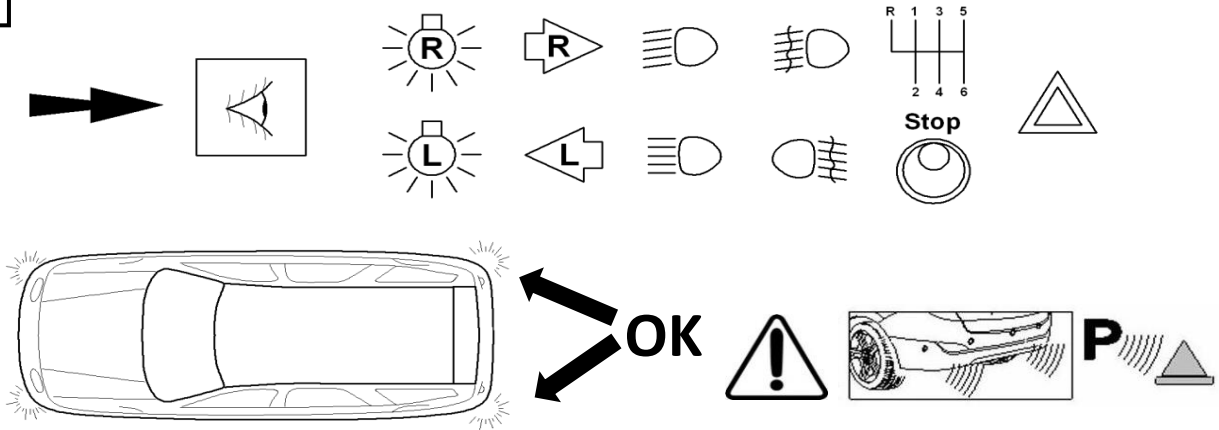

36

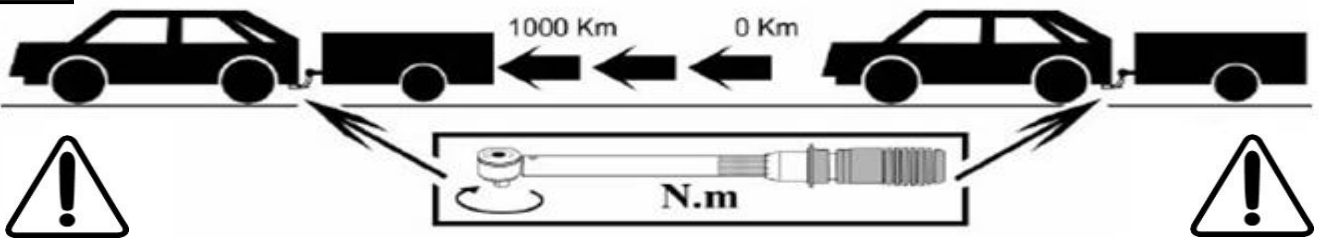

37



M10 CI 8.8 46 Nm
 M10 CI 10.9 60 Nm
 M12 CI 10.9 100 Nm
 M16 CI 8.8 195 Nm

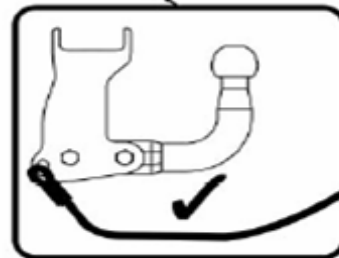
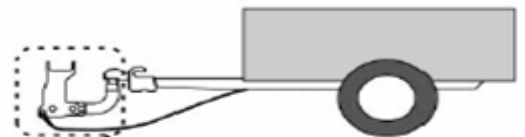
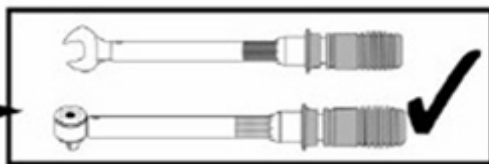

38

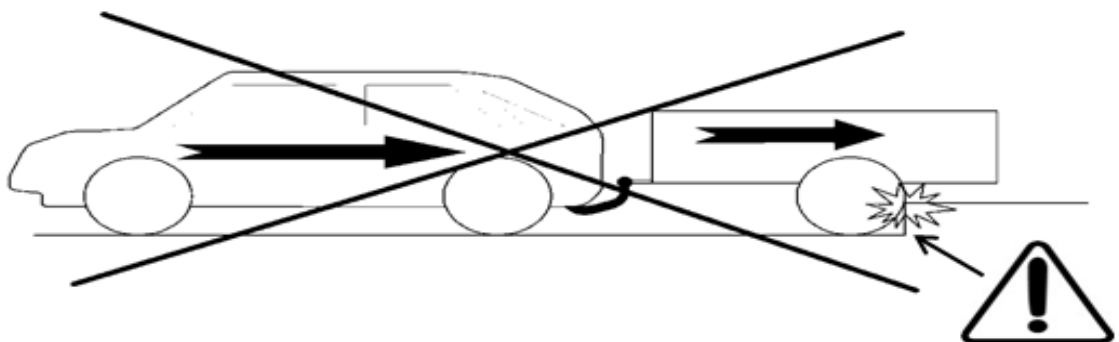

FRA

Les instructions de montage et/ou d'utilisation prescrites par le constructeur, dans ce présent document, sont établies en fonction des spécifications techniques en vigueur à la date d'établissement du document. Elles sont susceptibles de modifications en cas de changements apportés par le constructeur à la fabrication des différents organes et accessoires des véhicules de sa marque. Ce produit ne doit pas être utilisé sur d'autres véhicules que ceux spécifiés en haut de la première page de la notice de montage et/ou d'utilisation.

La sécurité est garantie si la conformité aux instructions de montage et/ou d'utilisation est suivie. Le non respect de cette notice dégage toute responsabilité du constructeur.

CZE

Pokyny pro montáž a/nebo pro použití stanovené výrobcem jsou v tomto dokumentu sepsány podle technických specifikací platných v den jeho vydání. V případě změn provedených výrobcem při výrobě různých součástí nebo příslušenství vozidla jeho značky mohou být upraveny.

Tento výrobek nesmí být používán na jiných vozidlech než na těch, která jsou specifikována v horní části první strany příručky pro montáž nebo uživatelské příručky.

Bezpečnost je zaručena, pouze pokud jsou dodrženy všechny pokyny pro montáž a/nebo pro použití. Za případné nedodržení pokynů této příručky nenese výrobce žádnou zodpovědnost.

DAN

Instruktionerne for montering og/eller brug som foreskrives af fabrikanten i herværende dokument, er udarbejdet ud fra de tekniske specifikationer, der var gældende på dagen, da dokumentet blev udfærdiget.

Instruktionerne kan ændres, hvis fabrikanten foretager ændringer vedrørende fremstillingen af de forskellige dele og tilbehør til det vedkommende bilmærke.

Dette produkt bør ikke anvendes på andre bilmodeller, end de der er angivet øverst på første side i monterings- og/eller brugsvejledningen.

Der er garanti for sikkerheden, hvis instruktionerne for montering og/eller anvendelse følges.

Hvis instruktionerne i denne vejledning ikke overholdes, bortfalder ethvert ansvar fra fabrikanten side

DEU

Die Montage- bzw. Bedienungsanleitungen, die im vorliegenden Dokument vom Hersteller vorgeschrieben werden, basieren auf den zum Zeitpunkt der Erstellung gültigen technischen Spezifikationen.

Sie unterliegen eventuellen Änderungen im Falle von Modifikationen seitens des Herstellers bei der Fertigung verschiedener Komponenten und des Zubehörs der Fahrzeuge seiner Marke.

Dieses Produkt darf bei keinem anderen als dem oben auf der ersten Seite dieser Montage- oder Bedienungsanleitung angegebenen Fahrzeug verwendet werden.

Die Sicherheit ist garantiert, insofern die Montage- oder Bedienungsanleitung befolgt wird. Bei Nichtbeachtung dieser Anleitung wird vom Hersteller keine Haftung übernommen.

ENG

The instructions for assembly and/or use provided by the manufacturer in this document reflect the technical specifications that were applicable at the time of writing.

These instructions are subject to change if the manufacturer makes changes to the production of the subsystems and accessories used in the brand's vehicles.

This product must only be used with the vehicles mentioned at the top of the first page of the assembly and/or user manual.

Following the instructions for assembly and/or use will guarantee safe use of the product. The manufacturer shall not be held liable if these instructions are not followed

ESP

Las instrucciones de montaje y/o de utilización prescritas por el constructor en este documento se han establecido en función de las especificaciones técnicas en vigor en la fecha de elaboración del documento.

Estas instrucciones pueden ser modificadas en caso de que el constructor introduzca cambios en la fabricación de las diferentes unidades y accesorios de los vehículos de su marca.

Este producto solamente se puede utilizar con los vehículos especificados en la parte superior de la primera página de las instrucciones de montaje y/o de utilización.

La seguridad del producto está totalmente garantizada si se siguen todas las instrucciones de montaje y/o de utilización. Sin embargo, el hecho de no respetar estas instrucciones exime al constructor de toda responsabilidad.

EST

Selles dokumendis sisalduvad tootjapoolsed paigaldus- ja/või kasutusjuhised vastavad dokumendi koostamise hetkel kehtivatele tehnilistele eeskirjadele.

Juhised võivad muutuda, kui tootja teeb muudatusi oma sõidukite erinevate komponentide ja lisavarustuse tootmises.

See toode on mõeldud kasutamiseks üksnes neil sõidukitel, mis on kirjas paigaldus- ja/või kasutusjuhendi esimese lehekülje ülalosas. Turvalisus on tagatud juhul, kui paigaldus- ja/või kasutusjuhiseid järgitakse. Kui seda juhendit ei järgita, on tootja vabastatud igasugusest vastutusest

FIN

Tässä kirjassa esitetyt asennus-/käyttöohjeet perustuvat siihen rakenteeseen, joka oli käytössä kirjaa laadittaessa. Asennus-/käyttöohjeet saattavat muuttua komponenteissa ja varusteissa käyttöön otettujen muutosten vaikutuksesta. Tätä tuotetta saa käyttää ainoastaan niissä autoissa, jotka on listattu asennus-/käyttöohjeen ensimmäisen sivun yläreunassa. Turvallisuus on taattu, jos noudatetaan asennus-/käyttöohjeita. Jos tämän kirjan ohjeita ei noudateta, valmistaja vapautuu kaikesta vastuusta.

GRE

Οι οδηγίες τοποθέτησης και/ή χρήσης που συνιστώνται από τον κατασκευαστή στο παρόν έντυπο έχουν καθοριστεί βάσει των τεχνικών προδιαγραφών που ίσχυαν κατά την ημερομηνία κατάρτισης του εντύπου. Ενδέχεται να υπάρξουν τροποποιήσεις σε περίπτωση που ο κατασκευαστής επιφέρει αλλαγές στην κατασκευή των διαφόρων οργάνων και εξαρτημάτων των αυτοκινήτων της μάρκας του. Απαγορεύεται η χρήση αυτού του προϊόντος σε άλλα αυτοκίνητα από εκείνα που αναφέρονται στην αρχή της πρώτης σελίδας του βιβλίου οδηγιών τοποθέτησης και/ή χρήσης. Η ασφάλεια είναι εγγυημένο εφόσον τηρούνται οι οδηγίες τοποθέτησης και/ή χρήσης. Η μη τήρηση αυτών των οδηγιών απαλλάσσει τον κατασκευαστή από οποιαδήποτε ευθύνη.

CRO

Uputstva za postavljanje i/ili korištenje propisana od strane proizvođača, u ovom dokumentu, sastavljena su na temelju tehničkih specifikacija koje su važeće na dan izdavanja ovog dokumenta. Podložna su promjenama u slučaju da proizvođač unese promjene pri proizvodnji različitih sklopova i dodatne opreme za vozila svoje marke. Ovaj proizvod ne smije se koristiti na na drugim vozilima osim na onim navedenim na vrhu prve stranice uputstva za postavljanje i/ili upotrebu. Sigurnost je zajamčena ako se strogo slijede pravila u uputstvima za postavljanje i/ili korištenje. Proizvođač ne preuzima odgovornost u slučaju nepoštivanja ovih uputstava.

HUN

A jelen dokumentumban szereplő, a gyártó által előírt szerelési és/vagy használati utasítások a kiadvány összeállításakor érvényben lévő műszaki jellemzők alapján lettek kialakítva. Amennyiben a gyártó a gépkocsi bizonyos szerkezeti elemeit megváltoztatja, akkor azzal együtt a szerelési/használati előírások is változhatnak. Ez a termék kizárólag a szerelési és/vagy használati útmutató első oldalának felső részén megadott gépkocsik esetén használható. A biztonságos használat csak a szerelési és/vagy használati utasítások pontos betartása esetén garantált. Az útmutató utasításainak be nem tartása esetén a gyártó semmilyen felelősséget nem vállal.

ITA

Le istruzioni di montaggio e/o d'uso prescritte dal costruttore, nel presente documento, sono elaborate in funzione delle specificazioni tecniche in vigore alla data dell'elaborazione del documento. Sono suscettibili di modifiche qualora il costruttore apporti delle modifiche nella fabbricazione di differenti organi e accessori dei veicoli recanti il suo marchio. Questo prodotto non deve essere utilizzato su veicoli diversi da quelli specificati in alto nella prima pagina delle istruzioni di montaggio e / o d'uso. La sicurezza è garantita nel caso in cui viene osservata la conformità alle istruzioni di montaggio e/o d'uso. Il mancato rispetto di queste istruzioni declina il costruttore da ogni responsabilità.

JPN

メーカー規定の取扱説明書や取付説明書は、各々技術仕様に応じて作成されたもので、作成日から有効となります。これらの説明書は、本メーカーによる車両の各コンポーネントおよびアクセサリーの製造変更にもない改訂されることがあります。取扱説明書や取付説明書は、各説明書の最初のページ上部に特定されている車両以外には使用できません。取扱説明書や取付説明書の記載内容を完全に遵守する場合のみ安全が保証されます。説明書の記載内容を遵守されない場合、メーカーは一切の責任を負うものではありません。

KOR

제작사에 의해 규정된 조립설명서 그리고/또는 사용설명서가 있는 이 서류는, 제작 날짜에 유효한 기술적인 기능을 설명하기 위해 기술되었습니다. 제작사의 다양한 장치와 부품의 수정은 사전예고 없이 이루어질 수 있습니다. 이 제품은 조립설명서 그리고/또는 사용설명서의 첫번째 페이지의 윗부분에 언급되어 있는 차량 외에 사용해서는 안됩니다. 조립설명서 그리고/또는 사용설명서를 준수하였을 경우에 안전이 보장됩니다. 이 문서의 내용을 준수하지 않았을 때 발생하는 모든 문제는 제작사가 책임을 지지 않습니다.

LTH

Montavimo ir / arba naudojimo instrukcijos, kurias šiame dokumente pateikė gamintojas, parašytos remiantis dokumento sudarymo metu galiojančiomis technikos specifikacijomis.

Instrukcijos gali keistis, jei gamintojas pakeistų tam tikrų šios markės automobilių elementų ar prietaisų gamybą.

Šį gaminį naudoti galima tik tuose automobiliuose, kurie nurodyti montavimo ir / arba naudojimo instrukcijų pirmojo puslapio viršuje. Laikantis montavimo ir / arba naudojimo instrukcijų, sauga garantuojama. Nesilaikant šiame dokumente išdėstytų nurodymų gamintojas neprisiima jokios atsakomybės.

LET

Ražotāja sniegtās montāžas un/vai lietošanas instrukcijas šajā dokumentā atbilst tai tehniskajai specifikācijai, kas ir spēkā dokumenta sastādīšanas datumā.

Tās var mainīties, ražotājam ieviešot izmaiņas savas markas automašīnu ierīču un piederumu ražošanā.

Šo izstrādājumu var izmantot tikai montāžas un/vai lietošanas rokasgrāmatas pirmajā lapā norādītajās automašīnās. Drošība ir garantēta, ja tiek ievērotas montāžas un/vai lietošanas instrukcijas. Šīs rokasgrāmatas neievērošana atbrīvo ražotāju no atbildības.

NLD

De door constructeur voorgeschreven aanwijzingen voor de montage en/of het gebruik die in dit document staan, zijn opgesteld volgens de technische richtlijnen die van kracht waren toen dit document werd samengesteld.

Deze kunnen veranderen indien de constructeur fabricagewijzigingen op onderdelen of accessoires van de auto's van zijn merk heeft aangebracht.

Dit product mag alleen worden gebruikt op de modellen die zijn aangegeven bovenaan de eerste bladzijde van de montage- en/of gebruiksaanwijzing.

De veiligheid is alleen gegarandeerd als conform de montage- en/of gebruiksaanwijzing is gewerkt.

De constructeur is niet aansprakelijk indien deze aanwijzingen niet zijn opgevolgd.

NOR

Anvisningene om montering og/eller bruk som produsenten har angitt i dette dokumentet, er basert på de tekniske spesifikasjonene som var gjeldende da dokumentet ble utarbeidet.

Disse kan bli gjenstand for modifikasjoner i forbindelse med produsentens endringer av fremstillingen av de ulike elementer og tilbehør for kjøretøy av dette merket.

Dette produktet må ikke brukes på andre kjøretøy enn de som er angitt øverst på første side i monterings- og/eller bruksanvisningen.

Sikkerheten er garantert hvis bruken er i samsvar med monterings- og/eller bruksanvisningen. Produsenten fraskriver seg alt ansvar ved manglende

overhold av disse anvisningene.

gene.

PLK

Instrukcje dotyczące montażu i/lub użytkowania zalecane przez producenta w niniejszej dokumentacji zostały opracowane na podstawie warunków technicznych

obowiązujących w dniu redagowania tekstu.

Mogą one ulec zmianom w przypadku wprowadzania przez producenta modyfikacji procesu produkcji różnych podzespołów i akcesoriów pojazdów tej marki

Wymieniony produkt powinien być używany wyłącznie w pojazdach przytoczonych w górnej części pierwszej strony instrukcji montażu i/lub instrukcji obsługi.

Przestrzeganie instrukcji montażu i/lub użytkowania gwarantuje bezpieczeństwo. W przypadku nieprzestrzegania niniejszych zaleceń, producent nie ponosi żadnej odpowiedzialności.

PTG

As instruções de montagem e/ou utilização prescritas pelo construtor, no presente documento, são estabelecidas em função das especificações técnicas em vigor, à data da sua

redacção. Estas instruções são susceptíveis de modificação, no caso de se verificarem alterações, introduzidas pelo construtor, no fabrico dos diferentes órgãos e acessórios das viaturas da sua marca.

Este produto não deve ser utilizado em veículos diferentes dos especificados na parte superior da primeira página do guia de montagem e/ou de utilização.

A segurança é garantida, se forem respeitadas as instruções de montagem e/ou utilização. O desrespeito por estas instruções iliba o construtor de qualquer responsabilidade.

ROM

Instrucțiunile de montare și/sau de utilizare prescrise de către constructor, în prezentul document, sunt stabilite în funcție de specificațiile tehnice în vigoare la data redactării documentului.

Ele sunt susceptibile de a fi modificate în cazul schimbărilor aduse de constructor în fabricarea diferitelor organe și accesorii ale vehiculelor mărcii sale. Acest produs nu trebuie să fie utilizat pe alte vehicule decât cele specificate în partea de sus a primei pagini din manualul de montare și/sau de utilizare. Securitatea este garantată dacă conformitatea cu instrucțiunile de montare și/sau de utilizare este urmată.

Nerespectarea acestui manual anulează orice responsabilitate a constructorului.

RUS

Указания по установке и/или эксплуатации, описанные изготовителем в настоящем документе, соответствуют техническим условиям, действительным на момент составления руководства.

В случае внесения конструктивных изменений в изготовление деталей, узлов, агрегатов автомобиля данной модели, методы ремонта могут быть также соответственно изменены.

Это изделие должно использоваться только на автомобилях, перечисленных в верхней части первой страницы руководства по установке и/или эксплуатации.

Безопасность гарантируется лишь в случае неукоснительного следования указаниям руководства по установке и/или эксплуатации. Несоблюдение этих указаний снимает всякую ответственность с изготовителя.

SLK

Instrukcie na montáž a/alebo používanie predpísané výrobcom v tomto dokumente boli vypracované v závislosti od predpisov platných k dátumu vytvorenia tohto dokumentu.

Pri zmenách zavedených výrobcom počas výroby rôznych častí a príslušenstva vozidiel danej značky sa môžu tieto inštrukcie meniť.

Tento výrobok možno používať iba na vozidlá uvedené v hornej časti prvej strany návodu na montáž a/alebo používanie.

Bezpečnosť možno zaručiť iba pri dodržaní inštrukcií na montáž a používanie.

Nedodržanie tohto návodu zbavuje výrobcu akejkoľvek zodpovednosti.

SLV

Navodila za montažo in/ali uporabo, ki jih določa proizvajalec v tem dokumentu, so v skladu s tehničnimi specifikacijami, ki veljajo na dan sestave tega dokumenta.

Te metode se lahko spremenijo v primeru, ko proizvajalec uvede spremembe pri izdelovanju različnih naprav in dodatne opreme na vozilih svoje znamke.

Ta proizvod se sme uporabiti le na vozilih, ki so določena na vrhu prve strani navodil za montažo in/ali uporabo.

Varnost je zagotovljena ob upoštevanju navodil za montažo in/ali uporabo. Proizvajalec ne prevzema nobene odgovornosti v primeru neupoštevanja teh navodil.

SWE

De monterings- och/eller användningsanvisningar som tillverkaren föreskriver i detta dokument har upprättats i enlighet med de tekniska specifikationer som gällde vid dokumentets tillkomst.

De kan ändras om tillverkaren av de olika delarna och tillbehören för respektive märke gör ändringar i produktionen.

Denna produkt ska inte användas på andra bilar än dem som angivits högst upp på monterings- och/eller användningsanvisningarnas första sida.

Säkerheten kan endast garanteras om monterings- och användningsanvisningarna följs. Om detta meddelande inte respekteras avsäger sig tillverkaren allt ansvar.

TRK

İşbu dokümanda, üretici tarafından öngörülen Onarım Metotları, dokümanın düzenlenme tarihinde yürürlükte olan teknik spesifikasyonlar doğrultusunda oluşturulmuştur.

Bu metotlar, üretici tarafından araçların çeşitli organ gruplarının ve aksesuarlarının imalatında yapılabilecek modifikasyonlar doğrultusunda değiştirilebilir.

Bu ürün, montaj ve/veya kullanım kitabının ilk sayfasının üst kısmında belirtilen araçlar dışında kullanılmamalıdır.

Montaj ve/veya kullanım talimatlarına uyulduğu sürece güvenlik garantisi altındadır. Bu kullanım kitabına uyulmaması halinde, üretici hiçbir şekilde sorumlu olmayacaktır.